

SPECIFICATIONS

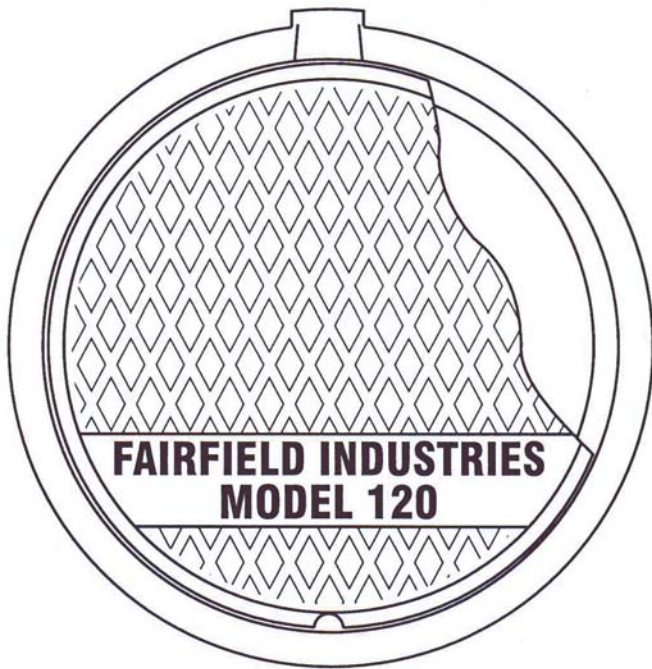

80/120 SERIES

HEAVY DUTY MULTI-PURPOSE MANHOLES

STANDARD FEATURES

- CAST IRON FRAME.
- NON-SKID GRID-LIKE DUCTILE IRON CAST COVER
- FRAME INCLUDES A PICKING NOTCH FOR EASY COVER.
- H-20 LOAD RAYING.
- GUSSETED FRAME FOR STRENGTH AND CONCRETE AND CONCRETE ADHESION.
- 14 GAUGE STEEL SKIRT.
- FULL ACCESS DESIGN.

TYPICAL APPLICATIONS

- FAIRFIELD 80/120 SERIES MANHOLES ARE USED IN SERVICE STATIONS, COMMERCIAL AND INDUSTRIAL APPLICATIONS WHERE STREET ACCESS IS REQUIRED TO UNDERGROUND PIPE CONNECTIONS.

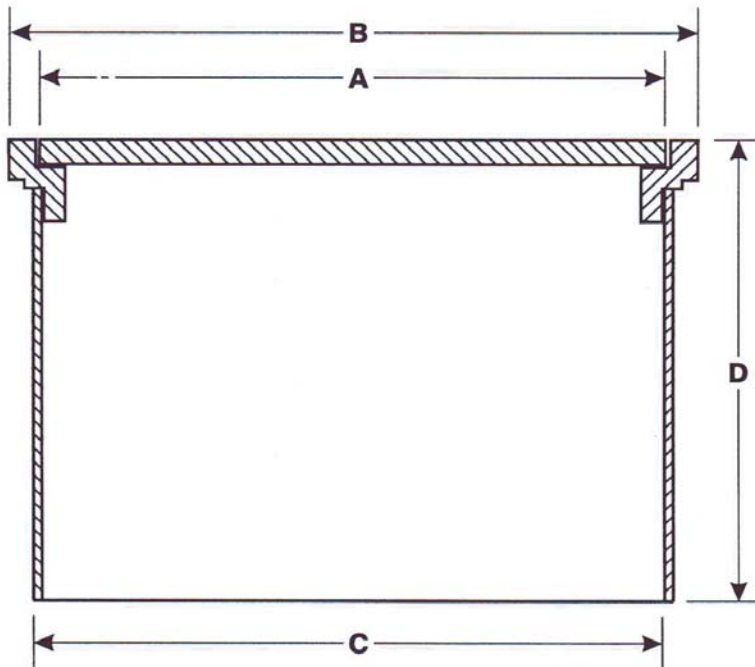

MULTI-PURPOSE MANHOLES

| MODEL | A | B | C | D |
|---------------|---------|--------|--------|--------|
| 80-8 | 8 1/4" | 9 1/2" | 7 3/4" | 8" |
| 80-12 | 8 1/4" | 9 1/2" | 7 3/4" | 12" |
| 120-8 | 12 1/4" | 14" | 12" | 8 1/2" |
| 120-12 | 12 1/4" | 14" | 12" | 12" |

MODEL NO: 80/120

DWG NO: 80/120

MULTI-PURPOSE
8" AND 12"
MANHOLES

NOTE: A) SPECIFY 9 5/8" (D) DIMENSION FOR ALL SHELL OIL APPLICATIONS.

FAIRFIELD INDUSTRIES, INC.

827 NORTH 6TH STREET NEWARK, NJ 07107

PHONE: 973-483-0100 FAX: 973-483-5333

www.fairfield-industries.com