

QUAD SERIES

WATER TIGHT MANHOLES

STANDARD FEATURES

- STEEL T-FRAME CONSTRUCTION.
- REINFORCED DIAMOND PLATE COVERS WITH 1/8" BUNA-N GASKET AND RECESSED STAINLESS STEEL RECESSED SET BOLTS.
- 14 GAUGE SKIRTS.
- ALL STEEL COATED WITH RUST PREVENTIVE PAINT.
- SPECIALLY DESIGNED RAIN TIGHT FRAMES AND COVERS ON INNER PORTS, CAST OF DUCTILE IRON.
- NO BOLTS REQUIRED TO KEEP INNER PORTS RAIN TIGHT.
- VARIOUS INNER ACCESS PORT ARRANGEMENTS AVAILABLE.
- OPTIONAL RETRO SPILL CONTAINERS AVAILABLE FOR 11 5/8" PORTS.
- VARIOUS RADDII AVAILABLE.
- CHANNEL-STYLE CONCRETE ANCHORS.

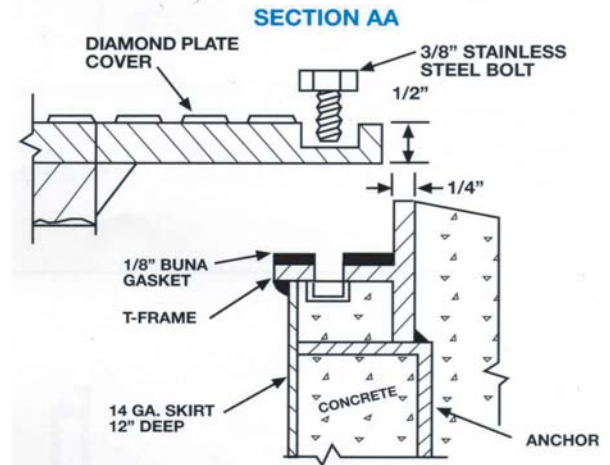
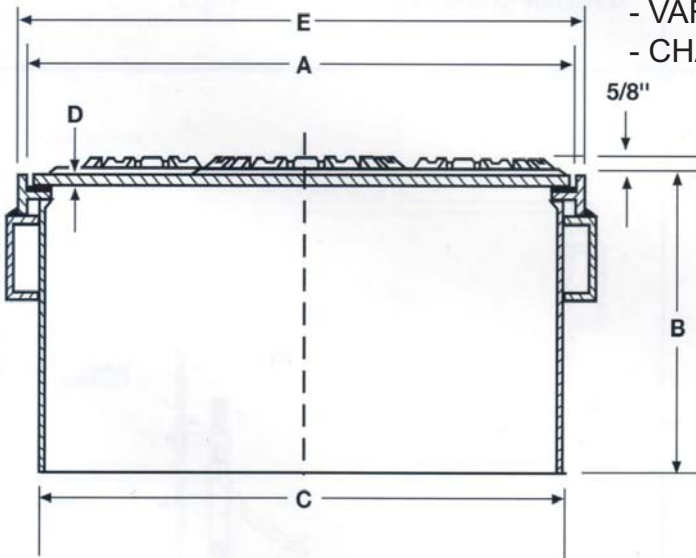
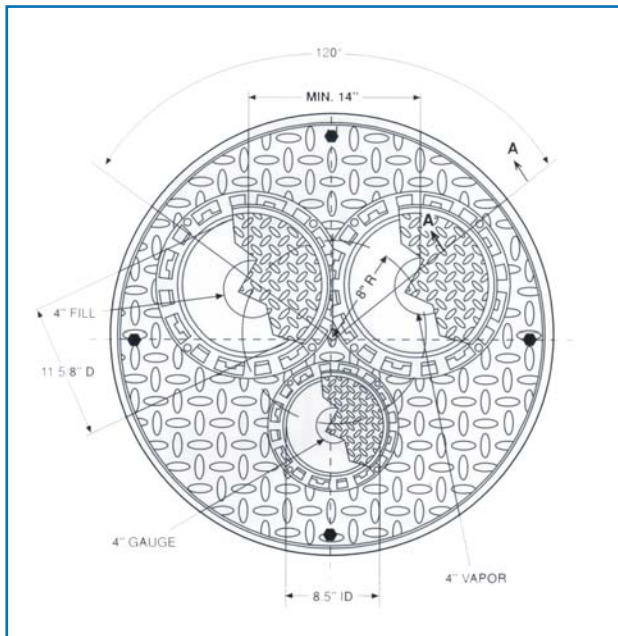

DUAL ACCESS SINGLE PORT MANHOLES

MODEL	A	B	C	D	E	F
363 WT	35 3/4"	13 1/2"	35"	1/2"	36 1/2"	(4) QTY
423 WT	42"	13 1/2"	41 1/2"	1/2"	43"	(4) QTY
483 WT	48"	13 1/2"	46 1/2"	1/2"	49"	(6) QTY

MODEL: QUAD ACCESS/TRIPLE PORT WT SERIES

QUAD ACCESS
MANHOLES
WATER TIGHT

NOTE: A) SEE FSC SERIES RETRO SPILL CONTAINERS FOR SPILL CONTAINMENT ON ANY 11 5/8" PORT.
B) BE SURE TO SPECIFY QUANTITY OF SPILL CONTAINERS REQUIRED WHEN ORDERING.

FAIRFIELD INDUSTRIES, INC.

827 NORTH 6TH STREET NEWARK, NJ 07107

PHONE: 973-483-0100 FAX: 973-483-5333

www.fairfield-industries.com

Copyright © 2008 Fairfield Industries, Inc. All rights reserved

OPTIONAL RETROFIT SPILL CONTAINMENT FOR MULTI-ACCESS MANHOLE INNER PORTS

Optional Spill Containers can be ordered with Manholes for one or two ports as required. Four styles are available. **Note:** Add “WT” suffix to model numbers of SCM-5 Retro Series when adapting to watertight multi-access manholes.

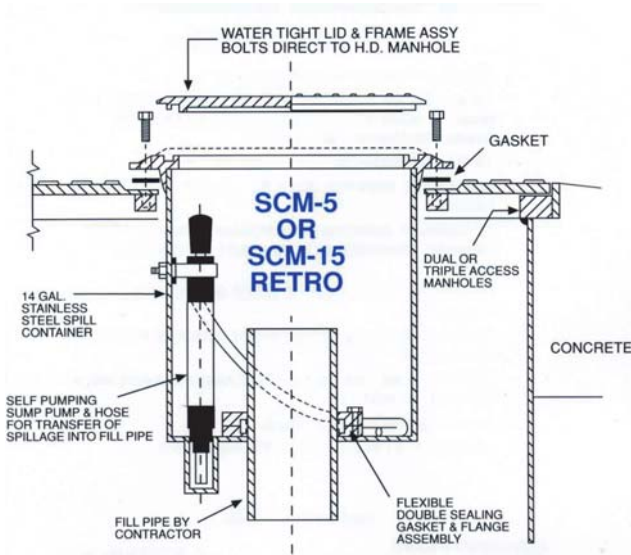

Standard “**SCM-5 RETRO**” Spill Containers mount directly to inner ports of multi-access manholes and seal around the outside of fill riser pipes. 5 or 15 gallon capacities available.

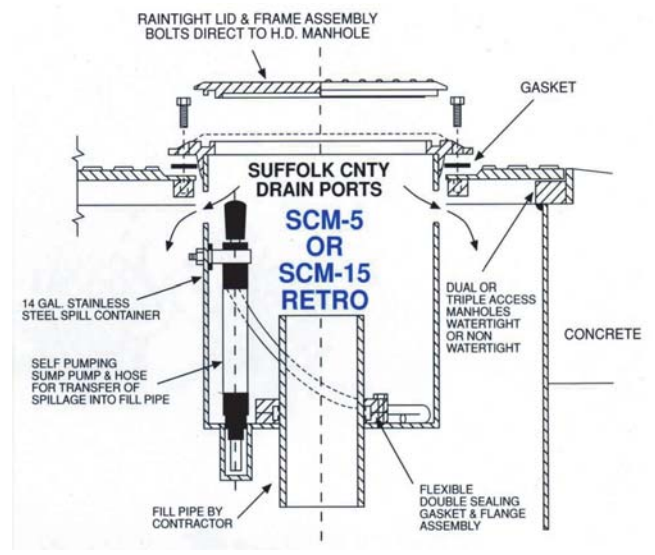

The “**SCM-5 Retro Suffolk**” is designed and mounts the same as the standard unit except includes drain ports in spill container which alleviates overflowing onto pavement and directs overflowing into lower tank sumps.

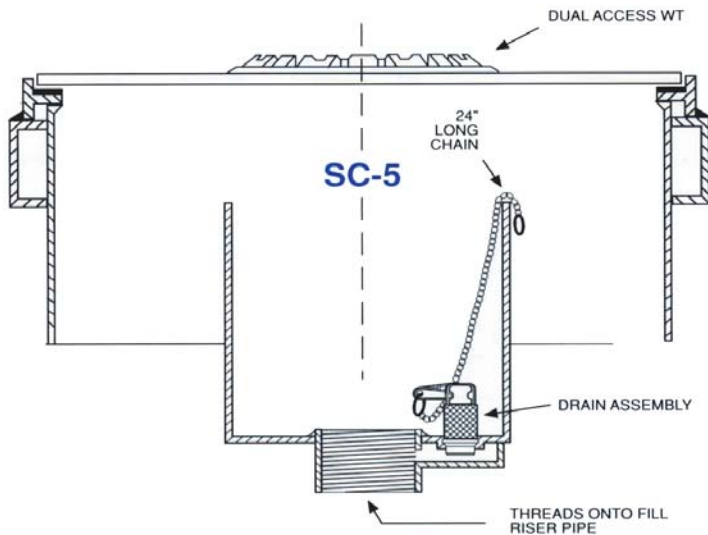

The “**SCM-5 Spill Container**” screws directly onto fill riser pipes and is independent to multi-access manholes above. Spill containers are aligned under surface ports and include a drain valve for draining spillage directly into fill riser pipe.

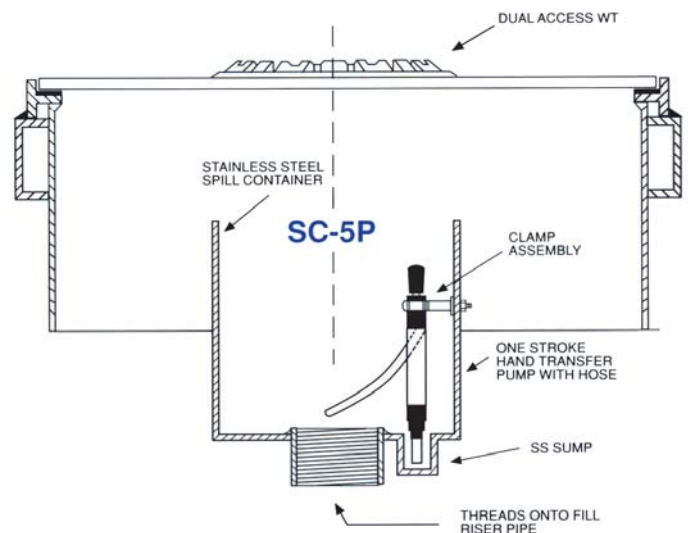

The “**SC-5P**” Spill Container is the same design as the SC-5 except includes a one stroke hand pump for transferring spillage back into riser pipe.