

ABOVE GROUND TANK STAINLESS STEEL SPILL CONTAINERS STANDARD FEATURES

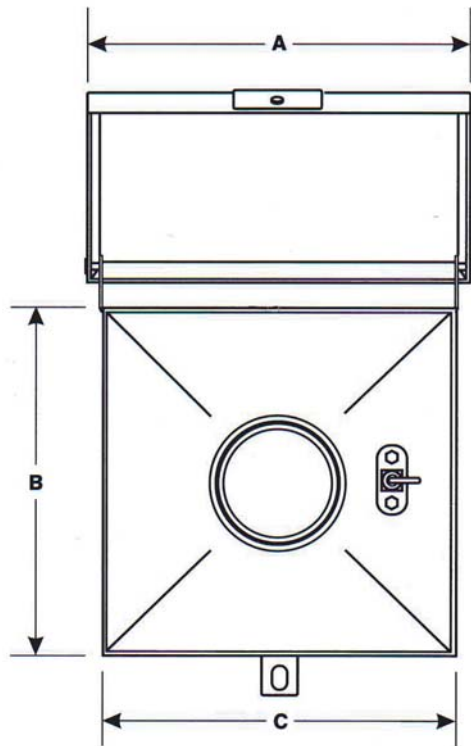

TOP VIEW

- MANUAL PULL DRAIN VALVE
- 14 GAUGE STAINLESS STEEL CONSTRUCTION, NOT PAINTED.
- RAIN TIGHT, LOCKABLE AND HINGED FLIP-TOP COVER THAT HOLDS ITSELF IN UPRIGHT POSITION.
- STANDARD 4" FPT CONNECTION.
- SPILL CONTAINER MOUNTS DIRECTLY TO FILL PIPE MALE NPT NIPPLE.
- BOTTOM CONTAINER DESIGNED TO DIRECT SPILLAGE TOWARD MANUAL DRAIN VALVE.
- 7 GALLON CAPACITY STANDARD.
- INDOOR OR OUTDOOR.
- AVAILABLE IN LARGER CAPACITIES.
- CAN BE REDUCED FOR 3" OR 2" FILL PORTS.

OPTION

- WALL MOUNTING BRACKETS.

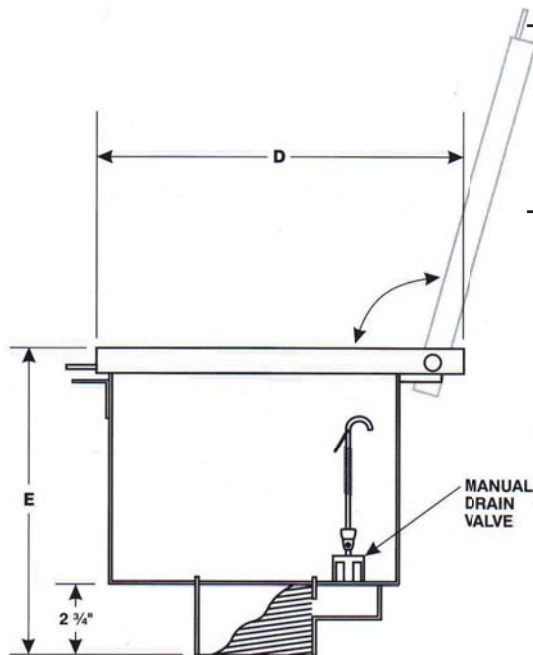

SIDE VIEW

ABOVE GROUND SPILL CONTAINERS

MODEL	A	B	C	D	E
AGSC-7	14 1/2"	14"	14"	17"	11 1/2"
AGSC-10	14 1/2"	14"	14"	17"	15 1/2"
AGSC-15	18 1/2"	18"	18"	21"	15"
AGSC-20	18 1/2"	18"	18"	21"	17"

MODEL NO: AGSC-7

DWG NO: AGSC-7

ABOVE GROUND TANK
STAINLESS STEEL
SPILL CONTAINER

NOTE: A) REDUCERS FOR 3" & 2" FILL PORTS ARE BY CONTRACTORS.

FAIRFIELD INDUSTRIES, INC.

827 NORTH 6TH STREET NEWARK, NJ 07107

PHONE: 973-483-0100 FAX: 973-483-5333

www.fairfield-industries.com