

RFP SERIES

REMOTE FILL PORTS FOR ABOVEGROUND TANKS

STANDARD FEATURES

- FREE STANDING, RAIN-PROOF 14 GA. STAINLESS STEEL ENCLOSURE FOR YEARS OF STRENGTH AND DURABILITY.
- HINGED AND PAD-LOCABLE DOOR
- 20 GALLON SPILL CONTAINMENT.
- 1" FPT DRAIN COUPLING IN BOTTOM FOR DRAINING.
- STANDARD 2", 3" OR 4" OUTLET CLOSE OFF BOOTS OF BUNA-N RUBBER.
- ANCHOR POINTS FOR ANCHORING TO CONCRETE PADS.
- ADEQUATE SIZED ENCLOSURE TO ACCOMMODATE VARIOUS OWNER INSTALLED INLET CONNECTIONS.
- OPTIONAL OUTLET PORTS AVAILABLE FOR VAPOR RECOVERY.
- OPTIONAL EXTERNAL PAINTING AVAILABLE.

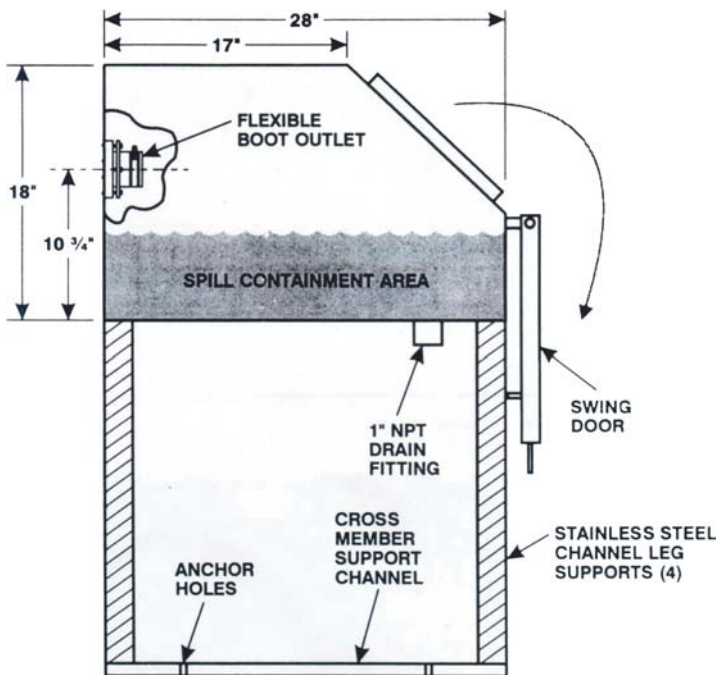
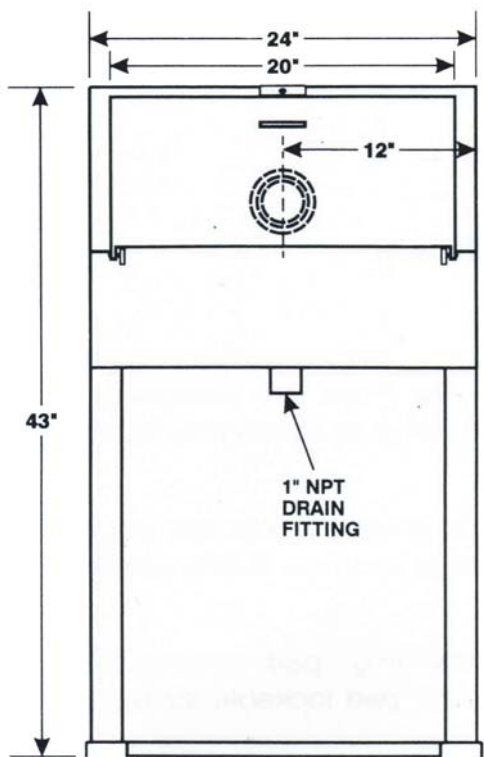

MODEL	DESCRIPTION
RFP-2	2" INLET
RFP-3	3" INLET
RFP-4	4" INLET

MODEL: RFP-2/3/4

REMOTE
FILL
PORT

NOTE:

FAIRFIELD INDUSTRIES, INC.

827 NORTH 6TH STREET NEWARK, NJ 07107

PHONE: 973-483-0100 FAX: 973-483-5333

www.fairfield-industries.com

Copyright © 2008 Fairfield Industries, Inc. All rights reserved

TYPICAL APPLICATION

The **FAIRFIELD INDUSTRIES** RFP Series Remote Ports are designed as a raintight fill box with spill containment for use in the filling of aboveground storage tanks.

These Remote Fill Ports are specifically used where delivery trucks are equipped with transfer pumps and are intended to contain spillage incurred during delivery for transfer back to AST.

The RFP Series of Remote Fill Ports are free standing, pad mountable and constructed of stainless steel for long life. Front door is pad lockable for restricted access and hinged down for full access.

Units are suitable for gasoline, oils and various chemical applications and come standard with a 1" FPT drain fitting. Outlet connections are flexible BUNA-N entry boots and are available in 2", 3" and 4" pipe sizes. Internal connections, valves and piping are field supplied and installed. Optional evacuation pump and sump are available on request.

