

SCM-15D

15-GALLON DOUBLE WALL SPILL CONTAINMENT MANHOLES

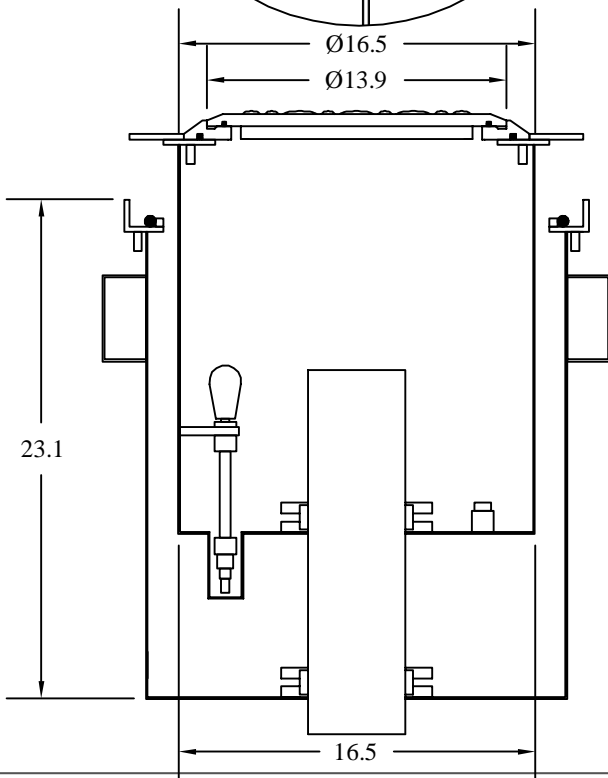
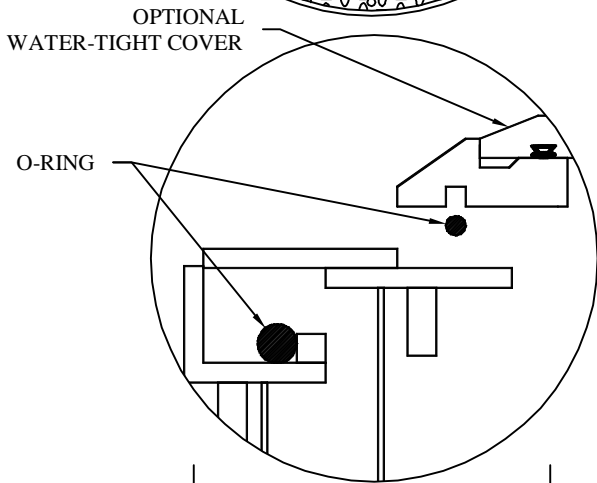
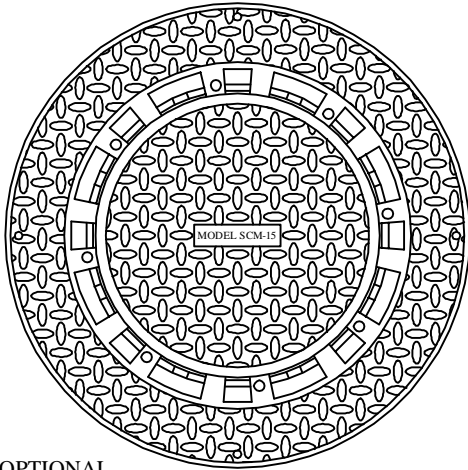

Fairfield Industries introduces the first slip-on style primary and secondary containment manhole complete with field-removable 15-gallon primary spill container. These spill containers can be specified for new installations or retrofitted in place of existing faulty manholes without excavating to the top of the tanks. Both primary and secondary containment chambers are sealed to the fill riser with Fairfield's proven double-sealing Victaulic Buna-N seals. Seals are replaceable from grade and held in place by ductile iron flange assemblies. Available in 2", 3", and 4" standard fill riser sizes.

FEATURES:

- Primary 15-gallon spill container is removable and replaceable with only four stainless steel cap screws. The primary container is sealed to the secondary container with a single, replaceable O-Ring. No concrete breaking required.
- The new removable primary 14ga. stainless steel slip-on spill container is secondarily contained in a 14ga. stainless steel containment chamber. Both chambers are factory tested and vacuum or pressure testing is possible in the field using the integral test port.
- Specially designed and proven rain-tight frame and cover assembly is cast of ductile iron and deters surface water without seals. Optional water-tight ("WT") Buna-N sealed cover is available by request.
- Primary containment manhole includes a hand operated one-stroke PVC pump and hose assembly used for the removal of spillage or water from containment bucket. This eliminates potential water intrusion into the tank.
- Channel-style concrete anchors on secondary containment chambers provide superior adhesion to concrete slab.

OPTIONS:

- Optional 2" grade access observation port is available on "OP" style units.
- Optional secondary containment piping or riser isolation connections are available upon request.

MODEL: SCM-15D

15-GALLON DOUBLE WALL SPILL
CONTAINMENT MANHOLES

FAIRFIELD INDUSTRIES, INC.

827 NORTH 6TH STREET, NEWARK, NJ 07107
PHONE: 973-483-0100 FAX: 973-483-5333
www.fairfield-industries.com

Copyright© Fairfield Industries, Inc. All rights reserved.