

SCM-5D-FL

5 GALLON DOUBLE WALL SPILL CONTAINMENT MANHOLES

FEATURES

- STAINLESS STEEL 5 GALLON PRIMARY SPILL CONTAINER.
- STAINLESS STEEL SECONDARY SPILL CONTAINER.
- 1 1/2" NPT OBSERVATION PORT.
- NYLON 6 PLUG WITH BUNA-N O-RING.
- 4" FLANGE & GASKET ASSEMBLY.
- CHEMTHANE COATING.
- MANUAL FLOAT GAUGE AVAILABLE.



CUSTOM EXTRUDED BUNA-N
DOVE TAIL O-RING

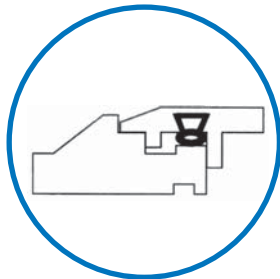

API PRODUCT I.D.
LOCATION

16" O.D.

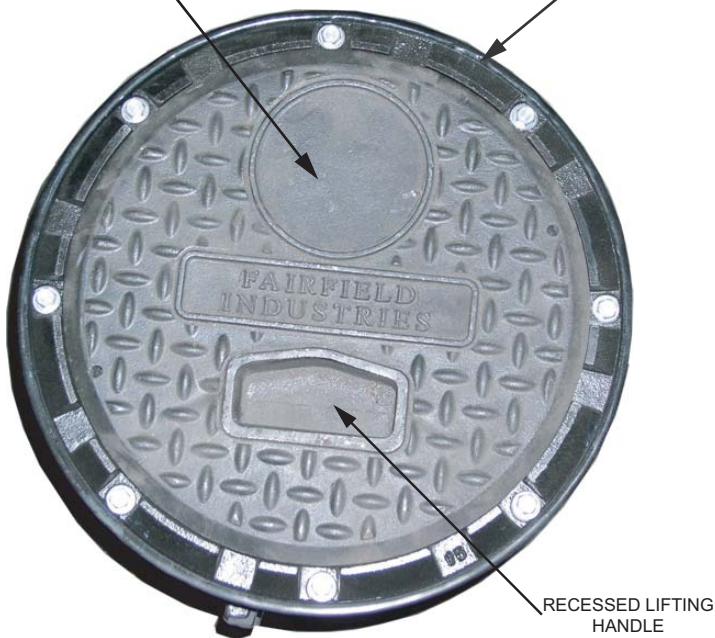

RECESSED LIFTING
HANDLE

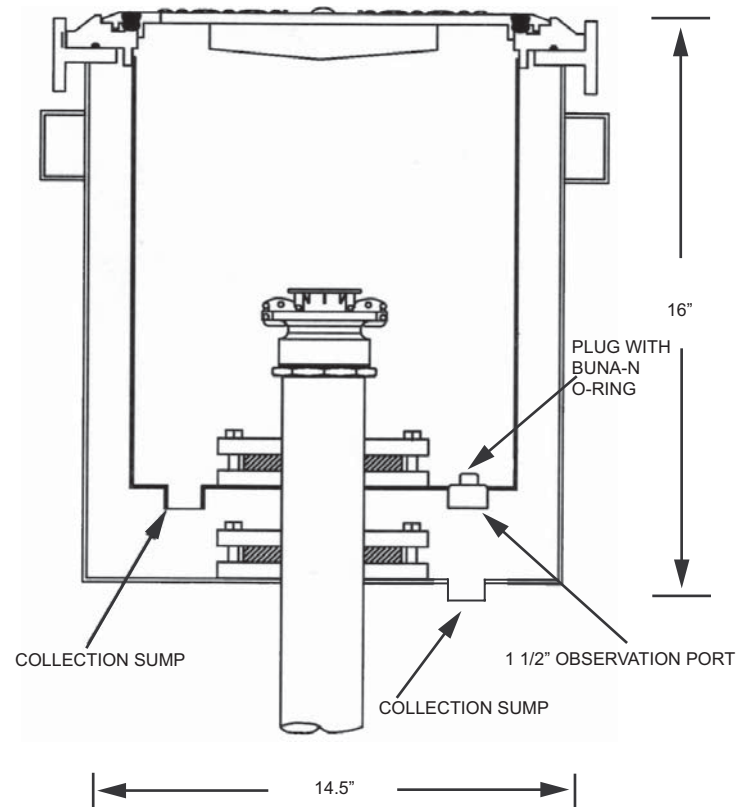

MODEL NO: SCM-5D-FL

5 GALLON SLIP-ON STYLE DOUBLE
WALL SPILL CONTAINER

FAIRFIELD INDUSTRIES INC.

827 North 6th Street Newark, NJ 07107
PHONE: 973-483-0100 FAX: 973-483-5333

www.fairfield—industries.com

Copyright© Fairfield Industries Inc. All rights reserved