

12" HEAVY DUTY MANHOLE

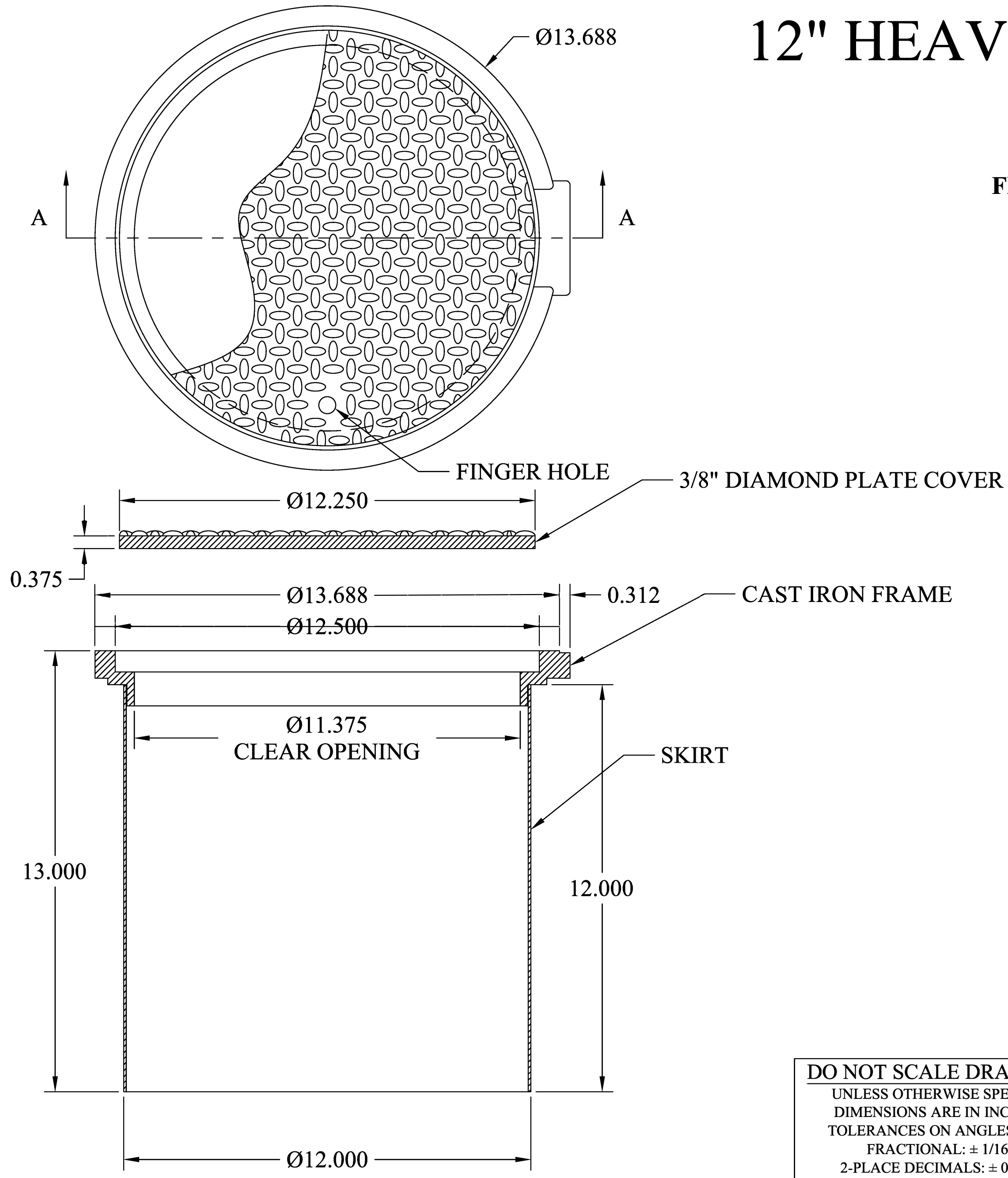

- FEATURES:**
- 11.375" DIA. CLEAR OPENING
 - CAST IRON FRAME
 - 3/8" DIAMOND PLATE STEEL COVER
 - 14 GAUGE STEEL SKIRT
 - FINGER HOLE FOR REMOVAL OF COVER
 - H-20 LOAD RATING

<p>DO NOT SCALE DRAWING UNLESS OTHERWISE SPECIED DIMENSIONS ARE IN INCHES. TOLERANCES ON ANGLES: ± 1° FRACTIONAL: ± 1/16 2-PLACE DECIMALS: ± 0.062 3-PLACE DECIMAL: ± 0.032</p>		<p>FAIRFIELD INDUSTRIES, INC 4483 CHOPPEE ROAD, GEORGETOWN SC 29440 PHONE: 843-461-3894 FAX: 843-461-3907</p>			
		<p>DESCRIPTION</p>		<p>120-12</p>	
<p>THIRD ANGLE PROJECTION</p>	<p>SIZE</p> <p>C</p>	<p>SCALE</p> <p>NTS</p>	<p>DWG.NO.</p> <p>S070717-2</p>	<p>REV.</p> <p>1</p>	<p>DRAWN BY</p> <p>S.BESHORE</p>
<p>This document is proprietary and confidential. No part of this document may be disclosed in any manner to a third party without the prior written consent of Fairfield Industries</p>		<p>DATE</p> <p>07/07/17</p>	<p>SHT.</p> <p>1 OF 1</p>		