

# 18" WATER TIGHT LOCKING MANHOLE

## FEATURES:

1. STEEL T-FRAME CONSTRUCTION
2. REINFORCED 3/8" THICK DIAMOND PLATE STEEL COVER WITH H-20 TRUCK LOAD RATING
3. THREE (3) CAM-LOCKS
4. 1/8" BUNA-N GASKET
5. 14GA. SKIRT
6. ALL STEEL COATED WITH A RUST PREVENTATIVE PAINT
7. CHANNEL-STYLE CONCRETE ANCHORS

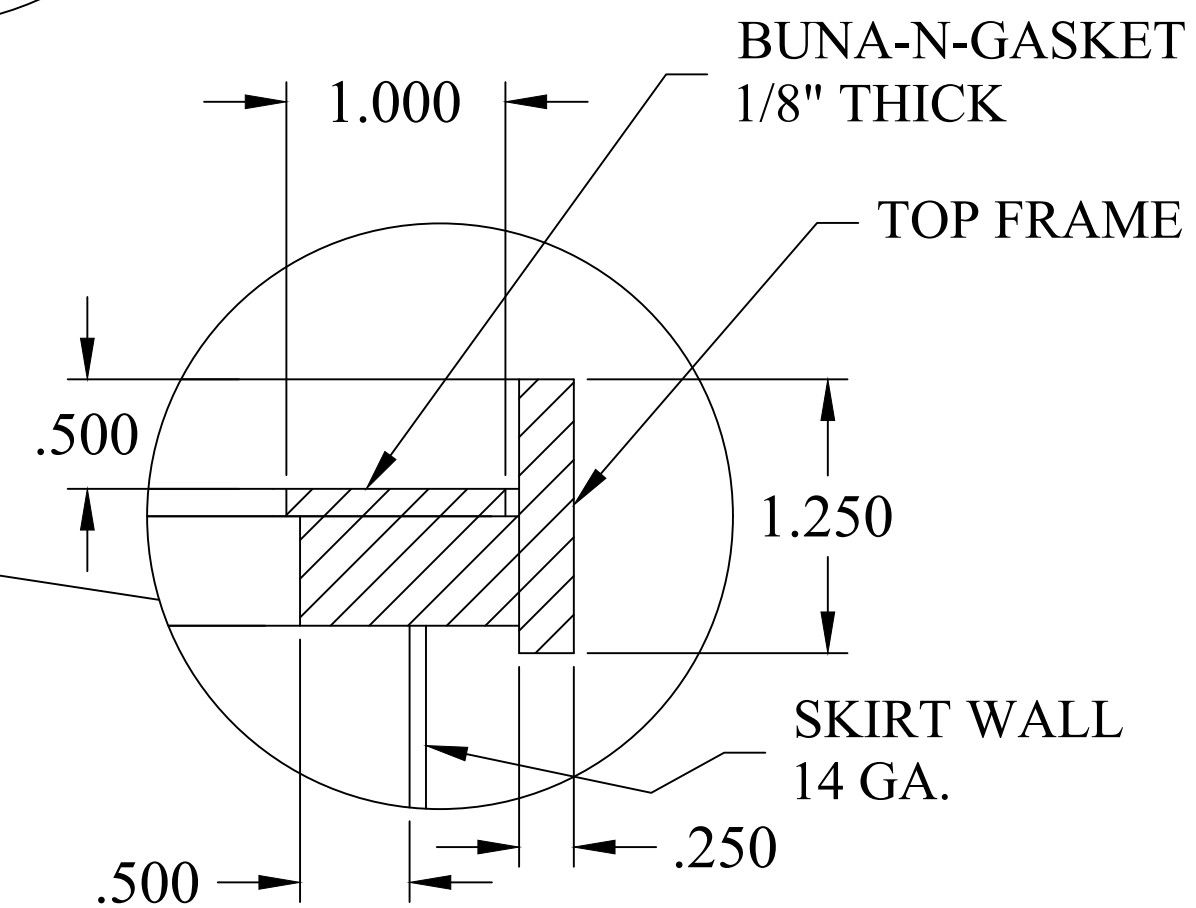
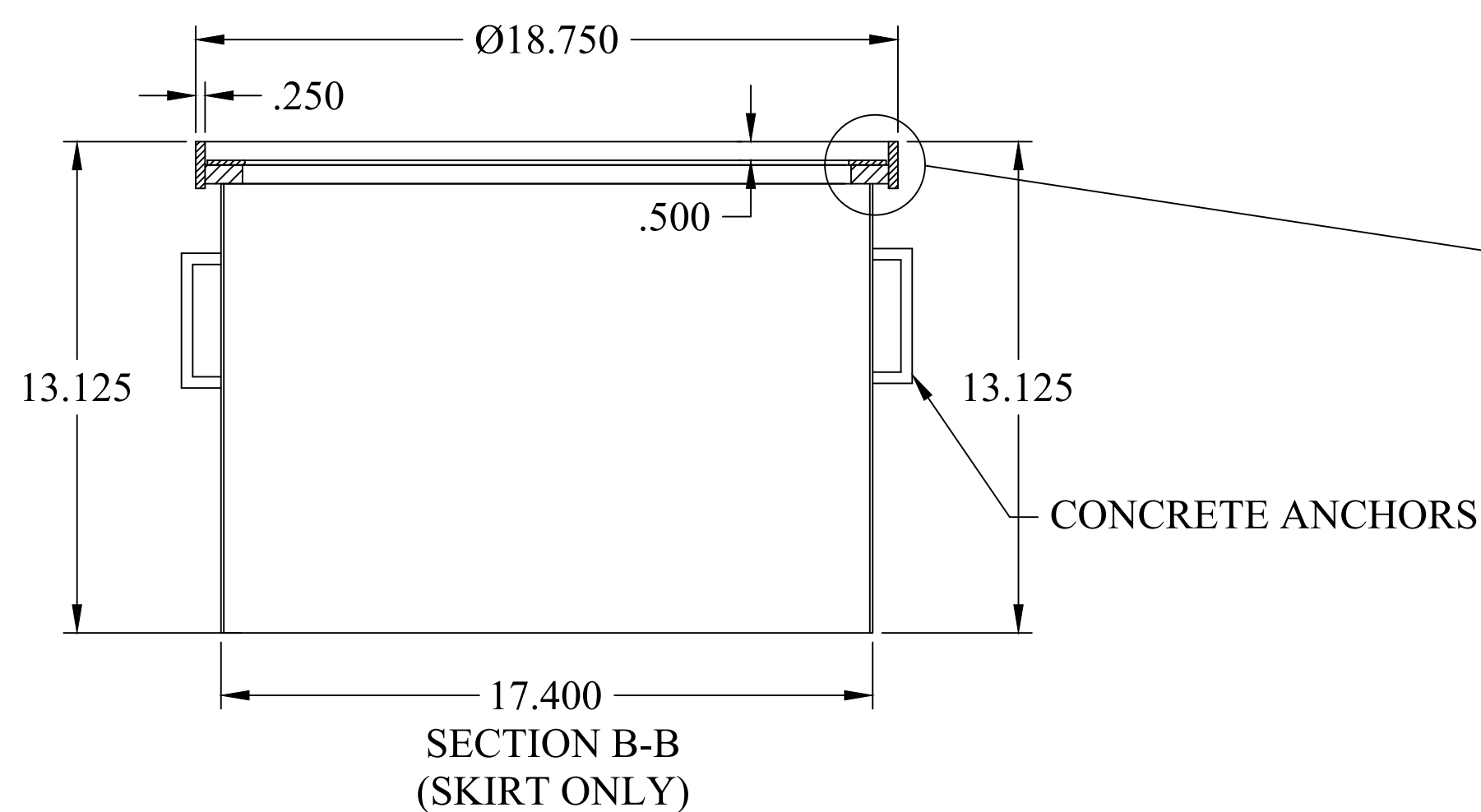
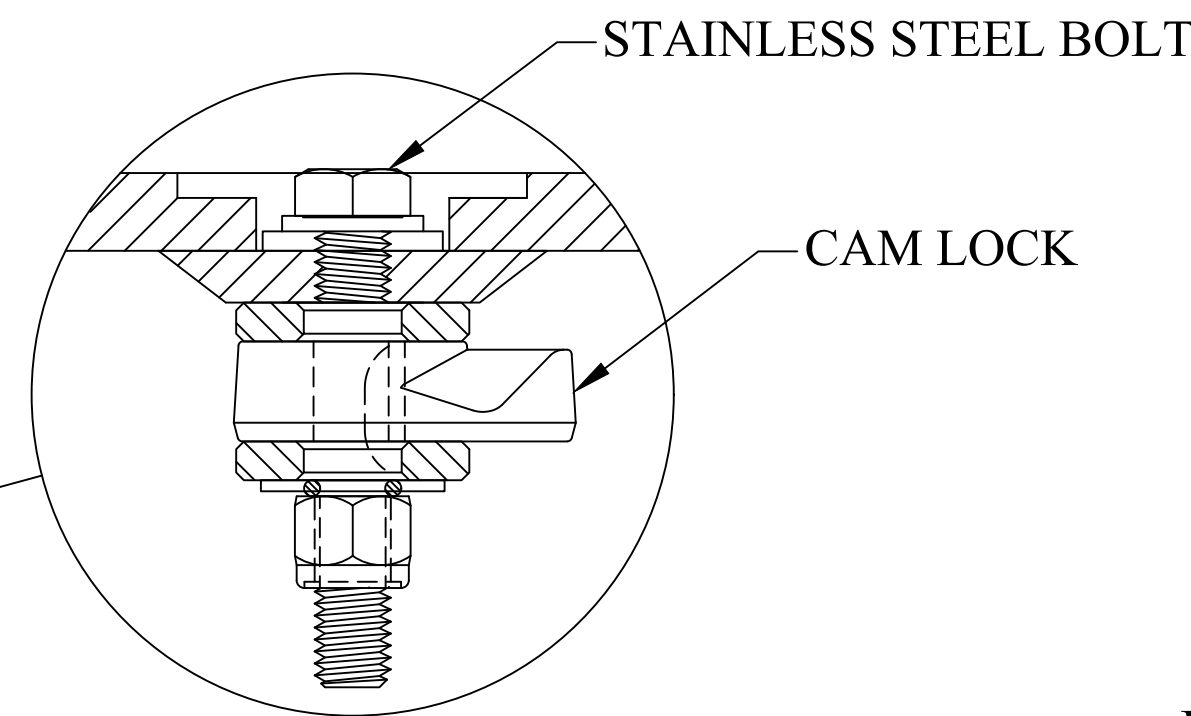
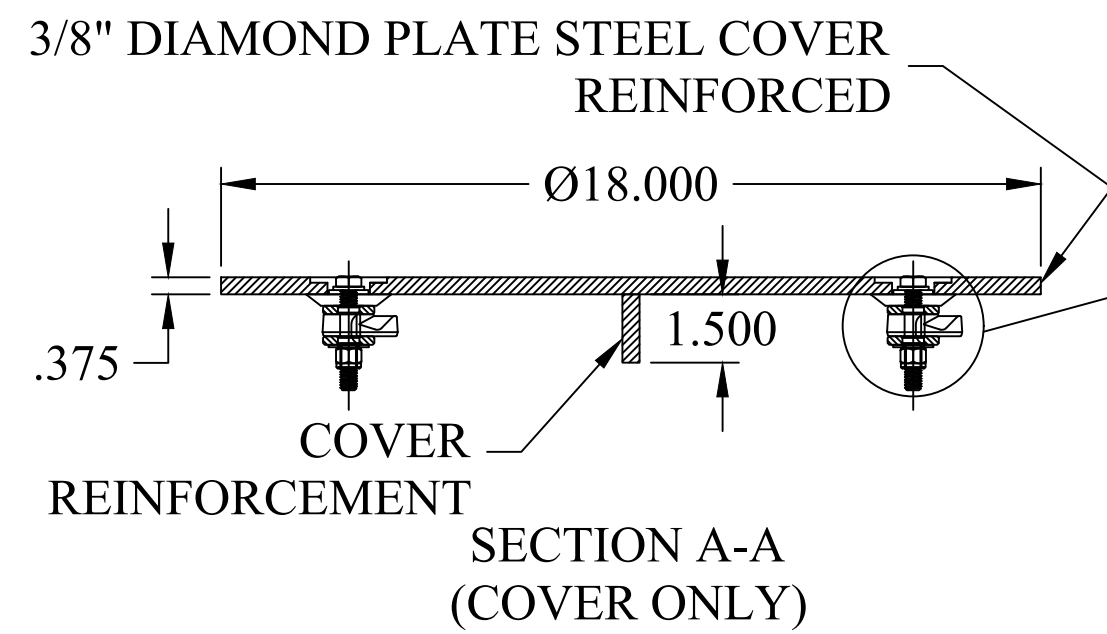
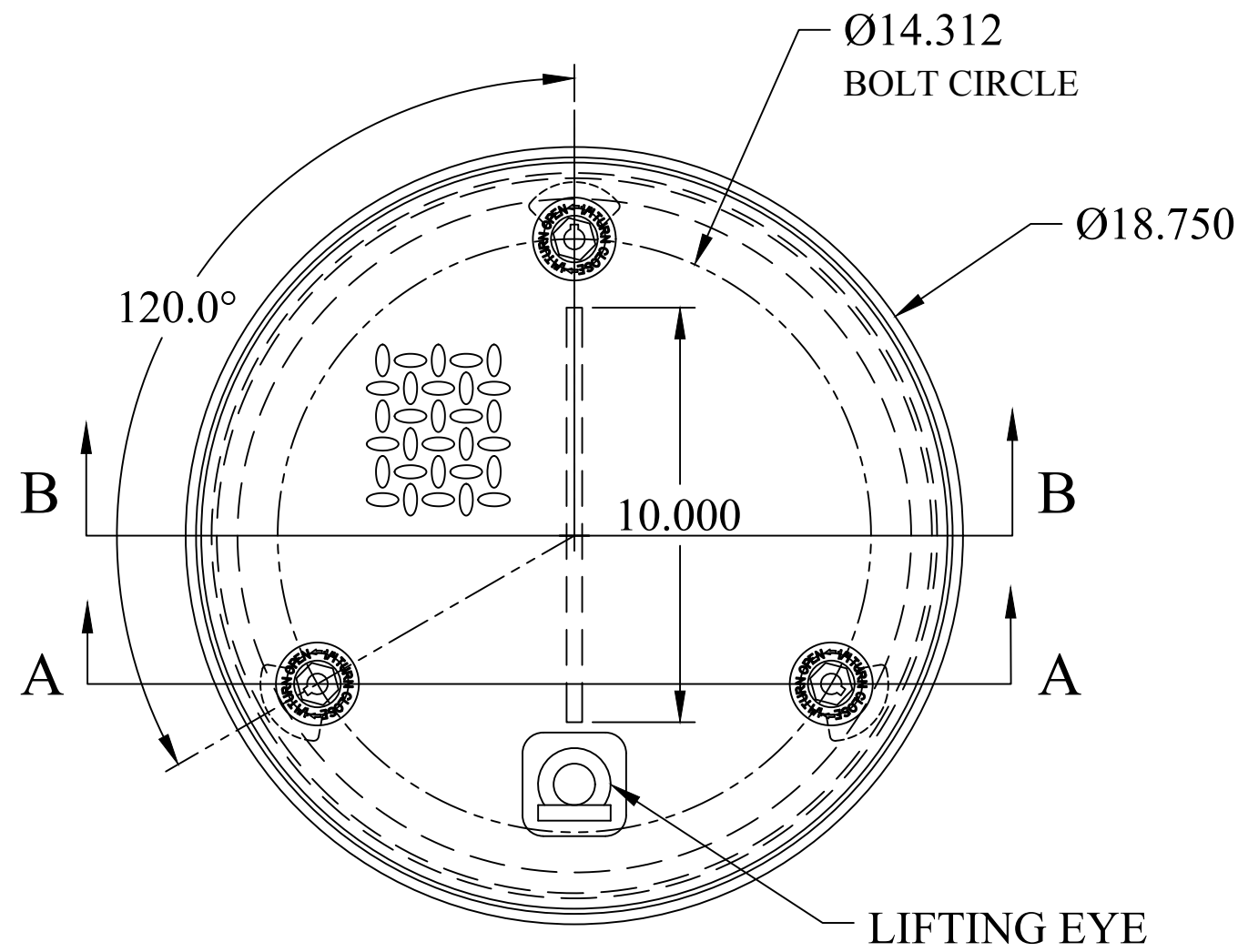

DO NOT SCALE DRAWING

UNLESS OTHERWISE SPECIFIED,  
DIMENSIONS ARE IN INCHES.

TOLERANCES ON ANGLES:  $\pm 1^\circ$   
FRACTIONAL:  $\pm 1/64$   
2-PLACE DECIMALS:  $\pm 0.05$   
3-PLACE DECIMALS:  $\pm 0.005$

THIRD ANGLE PROJECTION

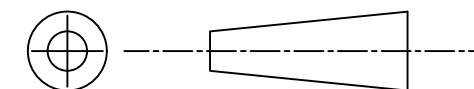

**FAIRFIELD INDUSTRIES, INC**

4483 CHOPPEE ROAD, GEORGETOWN SC 29440

PHONE: 843-461-3894 FAX: 843-461-3907

DESCRIPTION

180-WTL

SIZE <b>C</b>	SCALE <b>NTS</b>	DWG. NO <b>S042017-1</b>	C.REV <b>-</b>	REV <b>1</b>
------------------	---------------------	-----------------------------	-------------------	-----------------

DRAWN BY <b>S BESHORE</b>	DATE <b>04/20/17</b>	SHT <b>1 OF 1</b>
------------------------------	-------------------------	----------------------

This document is proprietary and confidential. No part of this document may be disclosed in any manner to a third party without the prior written consent of Fairfield Industries