

**FEATURES:**

- STEEL T-FRAME CONSTRUCTION
- 3/8" DIAMOND PLATE STEEL
- COVER WITH H-20 TRUCK LOAD RATING
- ONE (1) FINGER HOLE
- 14 GA. CARBON STEEL SKIRT
- ALL STEEL COATED WITH A RUST PREVENTATIVE PAINT
- CHANNEL-STYLE CONCRETE ANCHOR
- MADE IN USA

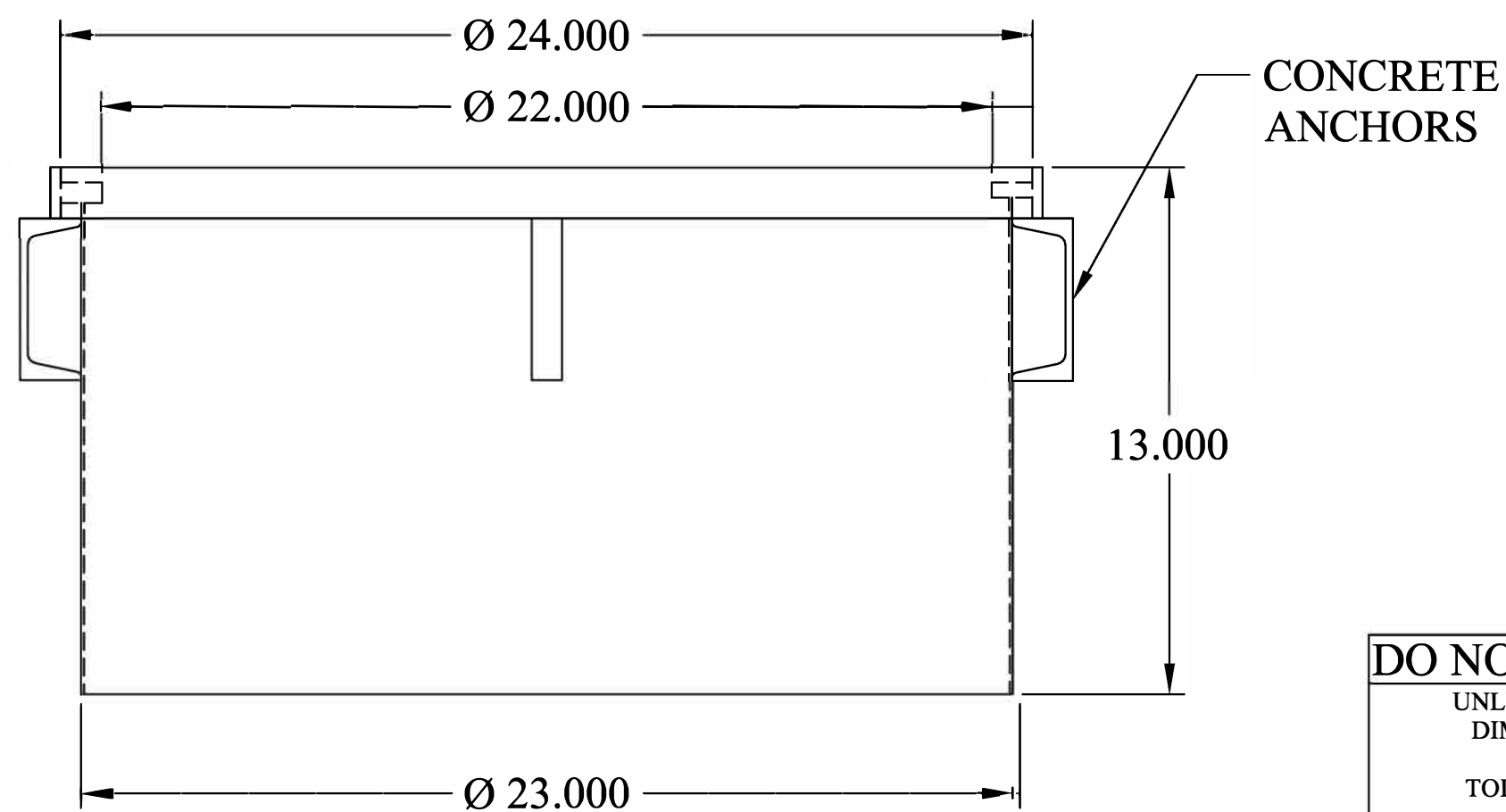
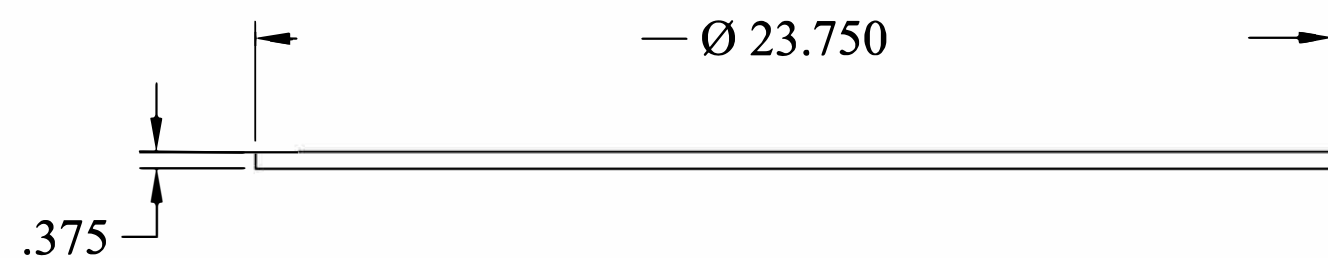

This document is proprietary and confidential. No part of this document may be disclosed in any manner to a third party without the prior written consent of Fairfield Industries

**DO NOT SCALE DRAWING**  
 UNLESS OTHERWISE SPECIFIED, DIMENSIONS ARE IN INCHES.  
 TOLERANCES ON ANGLES: ± 1°  
 FRACTIONAL: ± 1/64  
 2-PLACE DECIMALS: ± 0.05  
 3-PLACE DECIMALS: ± 0.005

THIRD ANGLE PROJECTION

<b>FAIRFIELD INDUSTRIES, INC</b>					
4483 CHOPPEE ROAD, GEORGETOWN SC 29440					
PHONE: 843-461-3894			FAX: 843-461-3907		
DESCRIPTION <b>240-HD</b>					
SIZE	SCALE	DWG. NO	C.REV	REV	
C	NTS	D101518-1	-	1	
DRAWN BY <b>D. NETTLES</b>		DATE <b>10/15/18</b>	SHT	1 OF 1	