

FEATURES:

- STEEL T-FRAME CONSTRUCTION
- 3/8" REINFORCED DIAMOND PLATE STEEL COVER WITH H-20 TRUCK LOAD RATING
- TWO (2) RECESSED STEEL HANDLE
- 14 GA. CARBON STEEL SKIRT
- ALL STEEL COATED WITH A RUST PREVENTATIVE PAINT
- CHANNEL-STYLE CONCRETE ANCHOR
- MADE IN USA

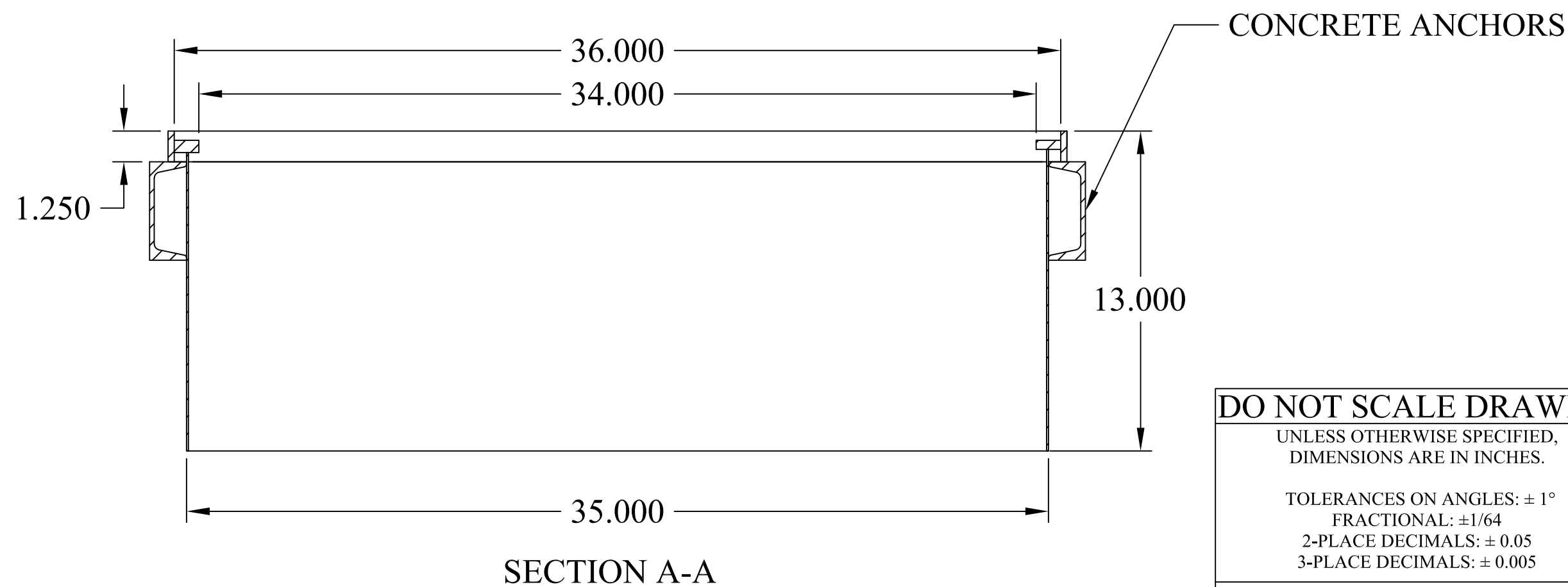
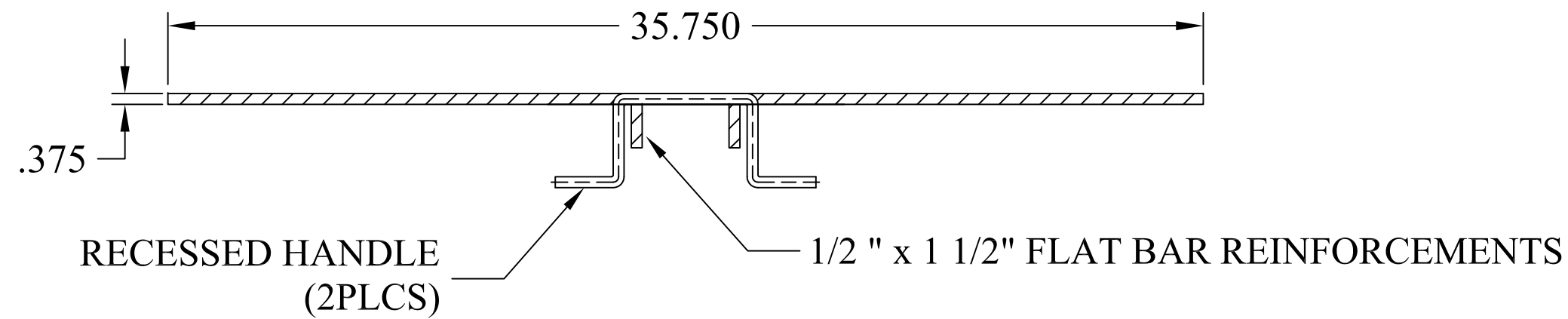

This document is proprietary and confidential. No part of this document may be disclosed in any manner to a third party without the prior written consent of Fairfield Industries

DO NOT SCALE DRAWING		FAIRFIELD INDUSTRIES, INC			
UNLESS OTHERWISE SPECIFIED, DIMENSIONS ARE IN INCHES.		4483 CHOPPEE ROAD, GEORGETOWN SC 29440			
TOLERANCES ON ANGLES: ± 1°		PHONE: 843-461-3894		FAX: 843-461-3907	
FRACTIONAL: ± 1/64		DESCRIPTION			
2-PLACE DECIMALS: ± 0.05		360 HD			
3-PLACE DECIMALS: ± 0.005		SIZE	SCALE	DWG. NO	C.REV
THIRD ANGLE PROJECTION		C	NTS	D101518-3	-
		DRAWN BY	DATE	SHT	REV
		DNETTLES	10/15/18	1 OF 1	1