

FEATURES:

- STEEL T-FRAME CONSTRUCTION
- 0.375 THK. DIAMOND PLATE COVER WITH H-20 TRUCK LOAD RATING
- FOUR (4) STAINLESS STEEL HEX BOLTS
- .125" THK. BUNA-N GASKET
- ONE (1) RECESSED LIFTING EYE
- 14 GA. CARBON STEEL SKIRT
- ALL STEEL COATED WITH A RUST
- PREVENTATIVE PAINT
- CHANNEL-STYLE CONCRETE ANCHORS
- MADE IN USA

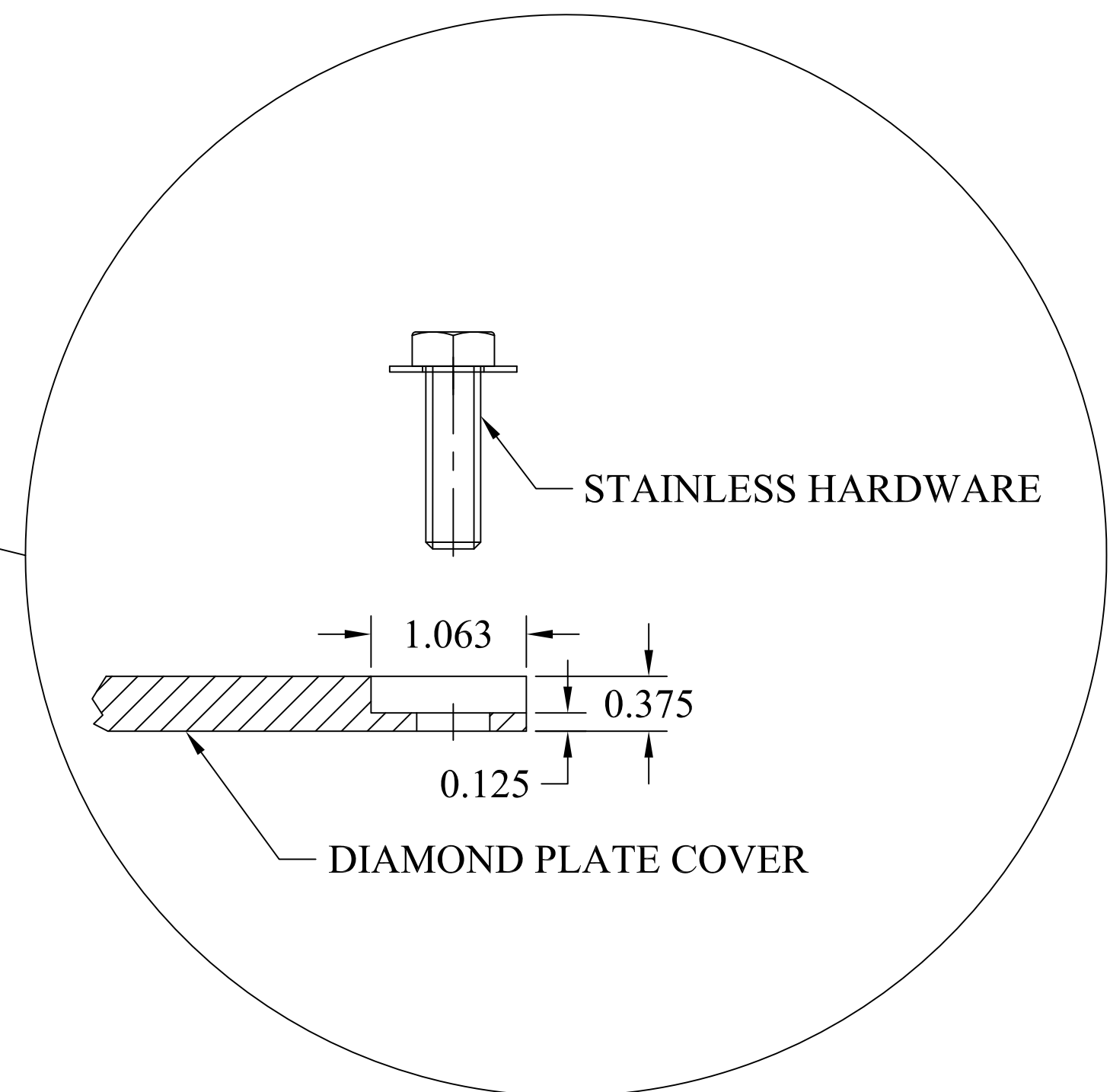
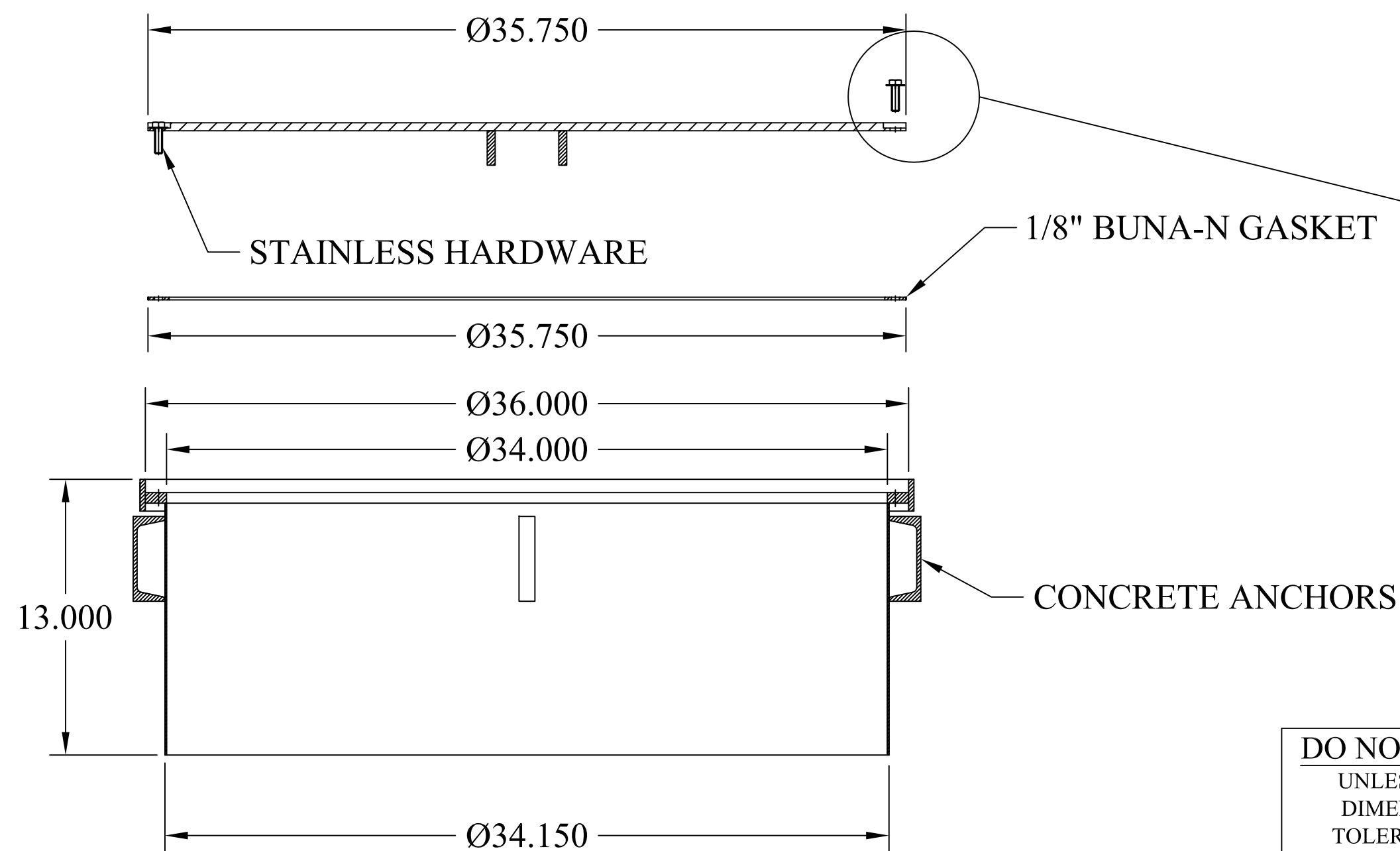

This document is proprietary and confidential. No part of this document may be disclosed in any manner to a third party without the prior written consent of Fairfield Industries

DO NOT SCALE DRAWING
UNLESS OTHERWISE SPECIED
DIMENSIONS ARE IN INCHES.
TOLERANCES ON ANGLES: ± 1°
FRACTIONAL: ± 1/16
2-PLACE DECIMALS: ± 0.062
3-PLACE DECIMAL: ± 0.032

THIRD ANGLE PROJECTION

FAIRFIELD INDUSTRIES, INC			
4483 CHOPPEE ROAD, GEORGETOWN SC 29440			
PHONE: 843-461-3894		FAX: 843-461-3907	
DESCRIPTION		360-WT	
SIZE	SCALE	DWG.NO.	REV.
C	NTS	D101618-4	1
DRAWN BY		DATE	SHT.
D NETTLES		10/16/18	1 OF 1