

FEATURES:

- STEEL T-FRAME CONSTRUCTION
- 0.375 THK. DIAMOND PLATE COVER WITH H-20 TRUCK LOAD RATING
- FOUR (4) STAINLESS STEEL HEX BOLTS
- .125" THK. BUNA-N GASKET
- TWO (2) RECESSED LIFTING EYES
- 14 GA. CARBON STEEL SKIRT
- ALL STEEL COATED WITH A RUST PREVENTATIVE PAINT
- CHANNEL-STYLE CONCRETE ANCHORS
- MADE IN USA

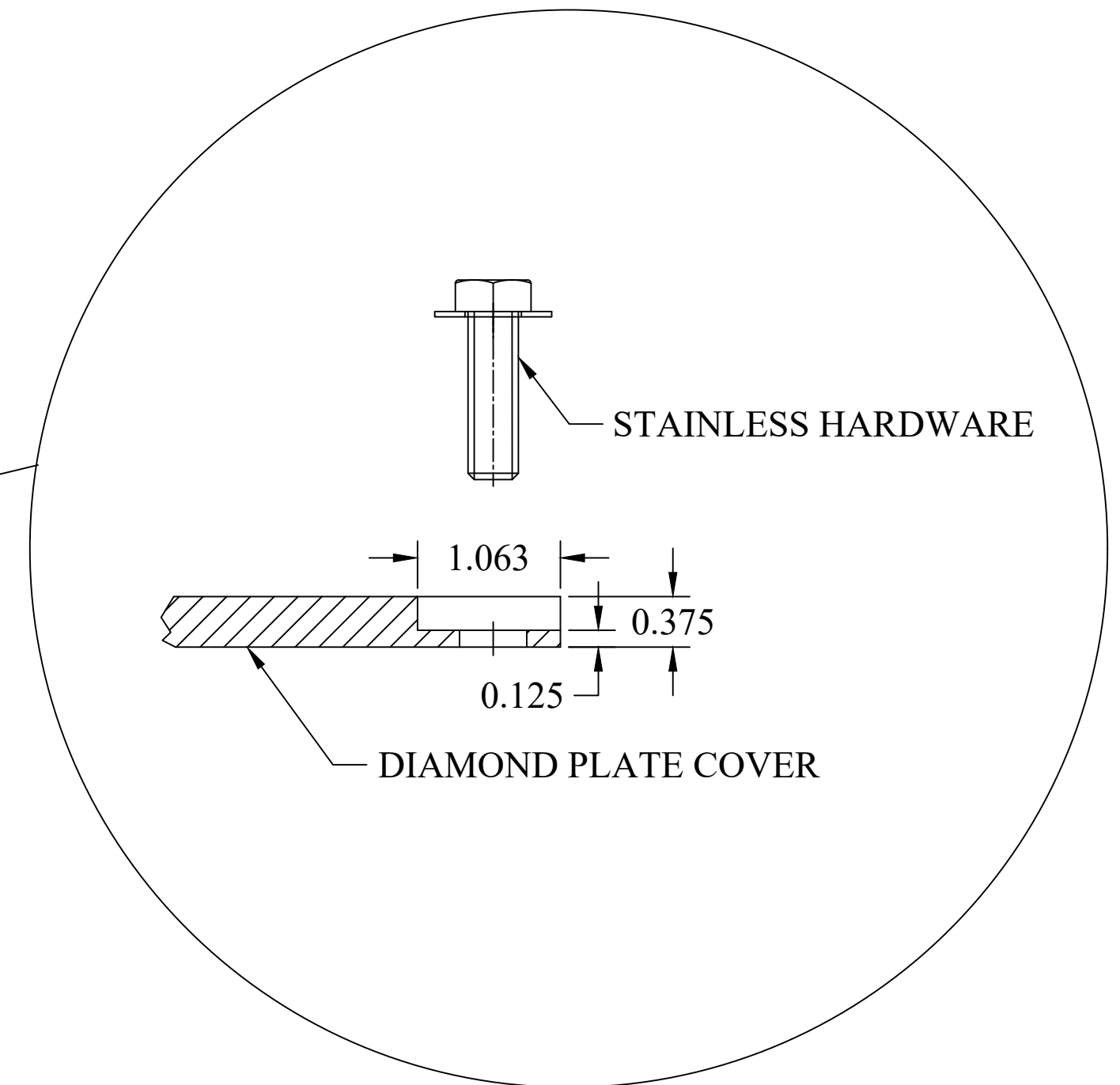
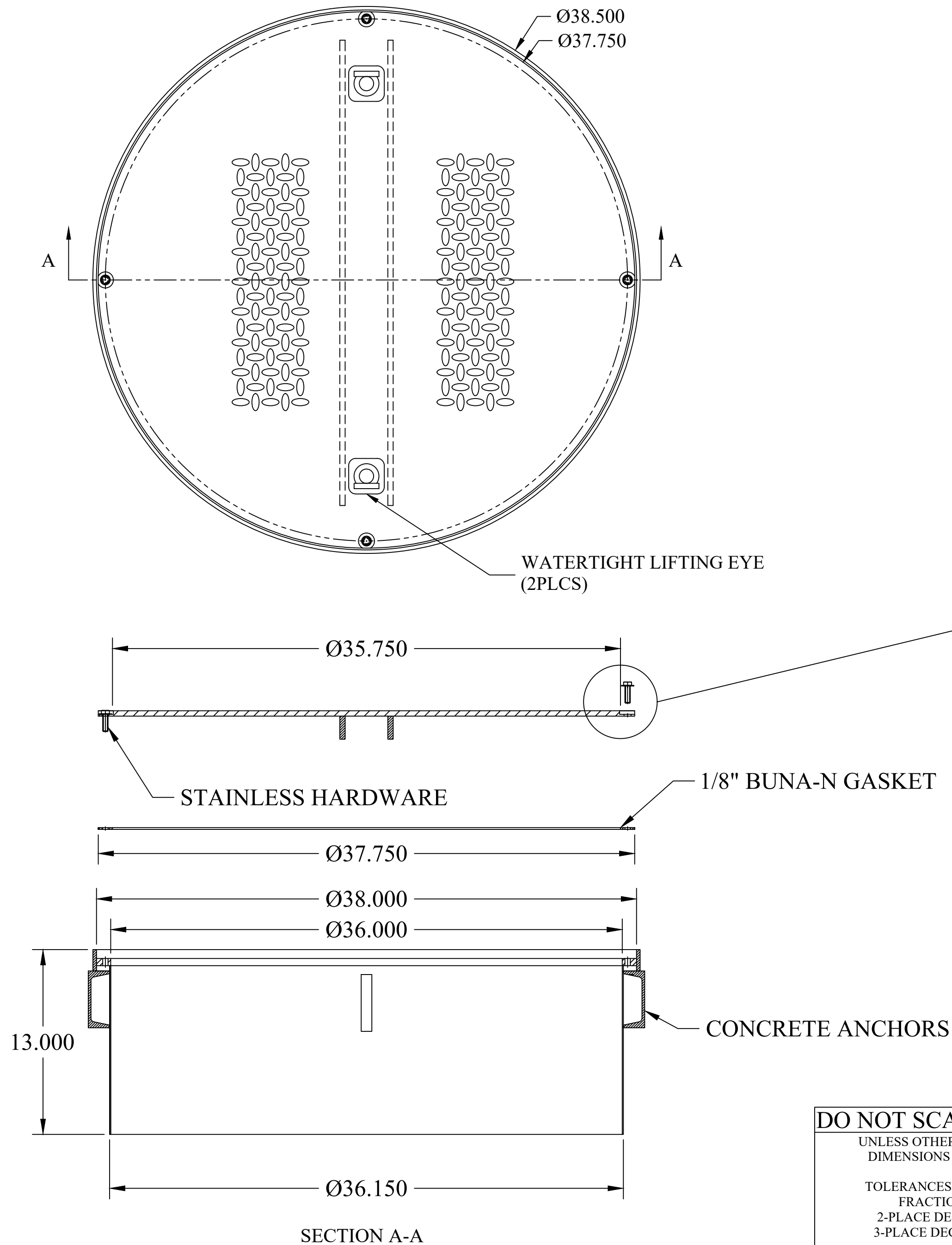

This document is proprietary and confidential. No part of this document may be disclosed in any manner to a third party without the prior written consent of Fairfield Industries

DO NOT SCALE DRAWING
 UNLESS OTHERWISE SPECIFIED, DIMENSIONS ARE IN INCHES.
 TOLERANCES ON ANGLES: ± 1°
 FRACTIONAL: ± 1/64
 2-PLACE DECIMALS: ± 0.05
 3-PLACE DECIMALS: ± 0.005
 THIRD ANGLE PROJECTION

FAIRFIELD INDUSTRIES, INC

4483 CHOPPEE ROAD, GEORGETOWN SC 29440
 PHONE: 843-461-3894 FAX: 843-461-3907

DESCRIPTION					
380-WT					
SIZE	SCALE	DWG. NO	C.REV	REV	
C	NTS	D101518-8	-	1	
DRAWN BY			DATE	SHT	
DNETTLES			10/15/18	1 OF 1	