

FEATURES:

1. STEEL T-FRAME CONSTRUCTION
2. 0.5" THK. REINFORCED DIAMOND PLATE STEEL COVERS WITH H-20 TRUCK LOAD RATING
3. FOUR (4) STAINLESS STEEL HEX BOLTS
4. 1/8" BUNA-N GASKET AND STAINLESS STEEL RECESSED HARDWARE
5. 14GA. CARBON STEEL SKIRT
6. TWO (2) WATER TIGHT LIFTING EYES
7. ALL STEEL COATED WITH A RUST PREVENTATIVE PAINT
8. CHANNEL-STYLE CONCRETE ANCHORS

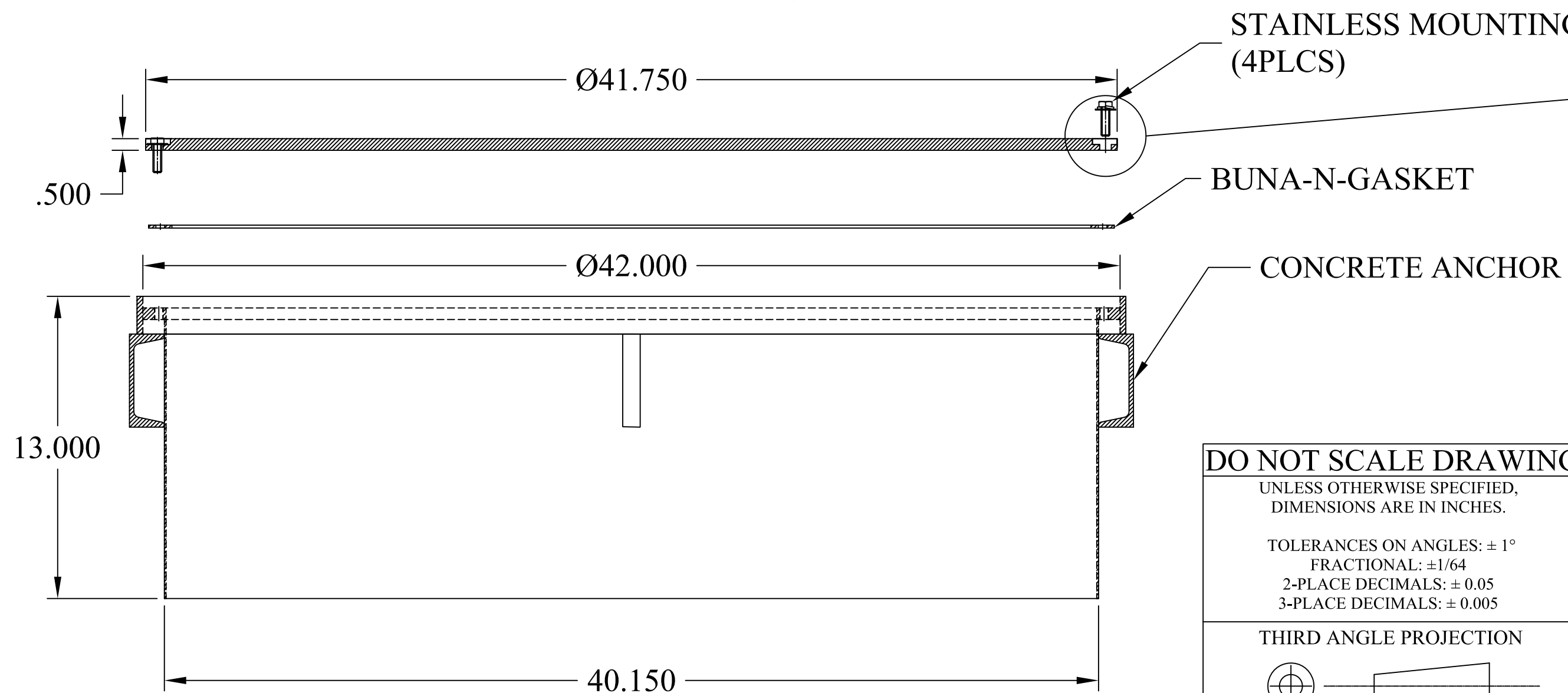
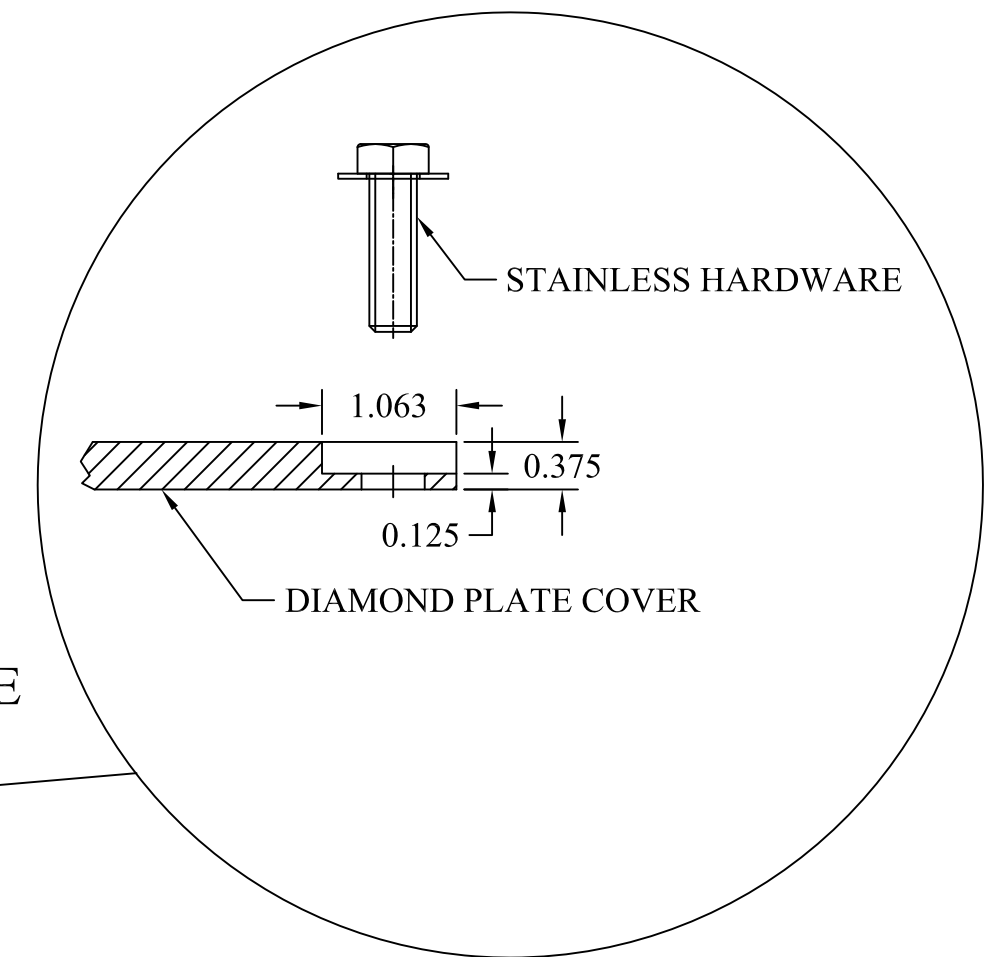
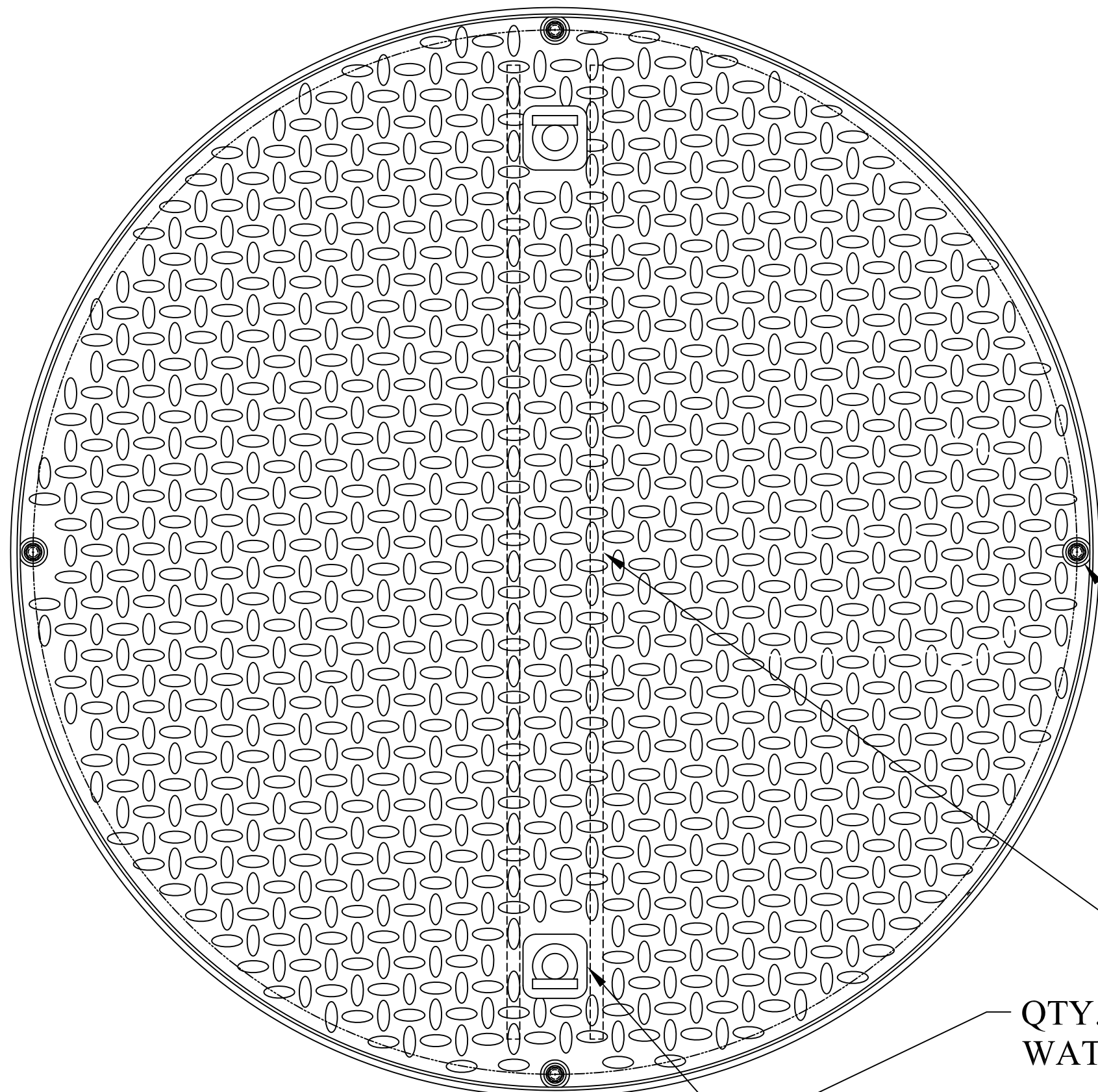

This document is proprietary and confidential. No part of this document may be disclosed in any manner to a third party without the prior written consent of Fairfield Industries

DO NOT SCALE DRAWING
UNLESS OTHERWISE SPECIFIED,
DIMENSIONS ARE IN INCHES.

TOLERANCES ON ANGLES: ± 1°
FRACTIONAL: ± 1/64
2-PLACE DECIMALS: ± 0.05
3-PLACE DECIMALS: ± 0.005

THIRD ANGLE PROJECTION

FAIRFIELD INDUSTRIES, INC

4483 CHOPPEE ROAD, GEORGETOWN SC 29440
PHONE: 843-461-3894 FAX: 843-461-3907

DESCRIPTION				
420-WT				
SIZE	SCALE	DWG. NO	C.REV	REV
C	NTS	D101718-1	-	1
DRAWN BY		DATE	SHT	
D. NETTLES		02/13/17	1 OF 1	