

FEATURES:

1. STEEL T-FRAME CONSTRUCTION
2. REINFORCED DIAMOND PLATE STEEL COVERS WITH H-20 TRUCK LOAD RATING
3. 14GA. SKIRT
4. TWO (2) RECESSED HANDLES LIFT HANDLES
5. 16" DIAMOND PLATE COVER
6. ALL STEEL COATED WITH A RUST PREVENTATIVE PAINT
7. CHANNEL-STYLE CONCRETE ANCHORS

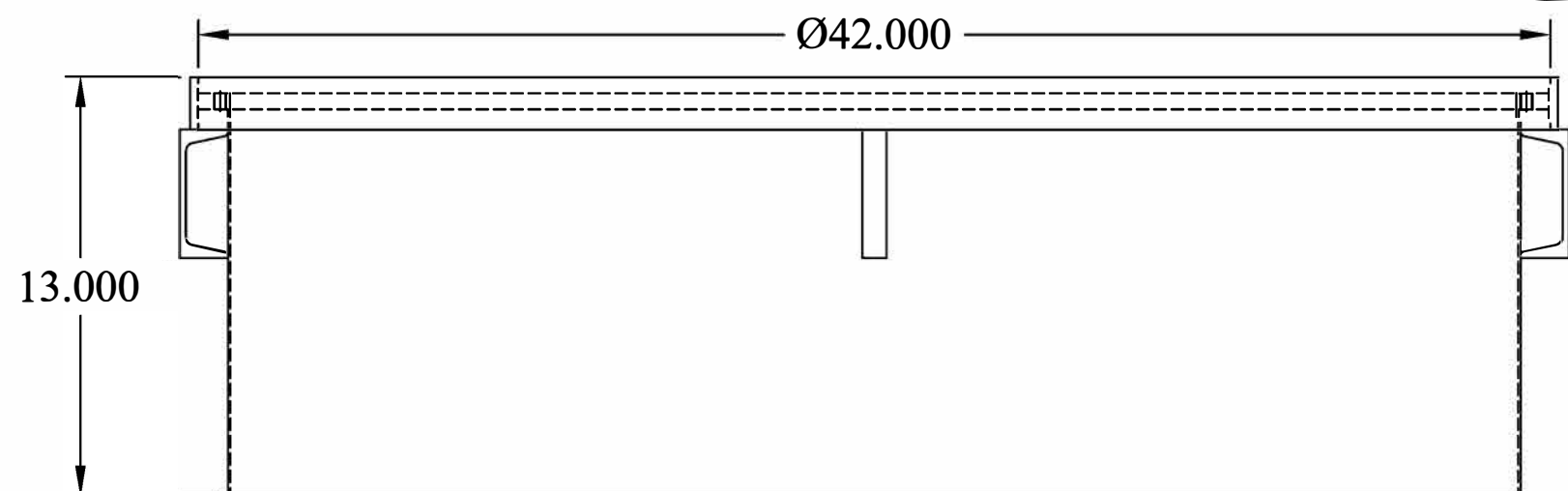
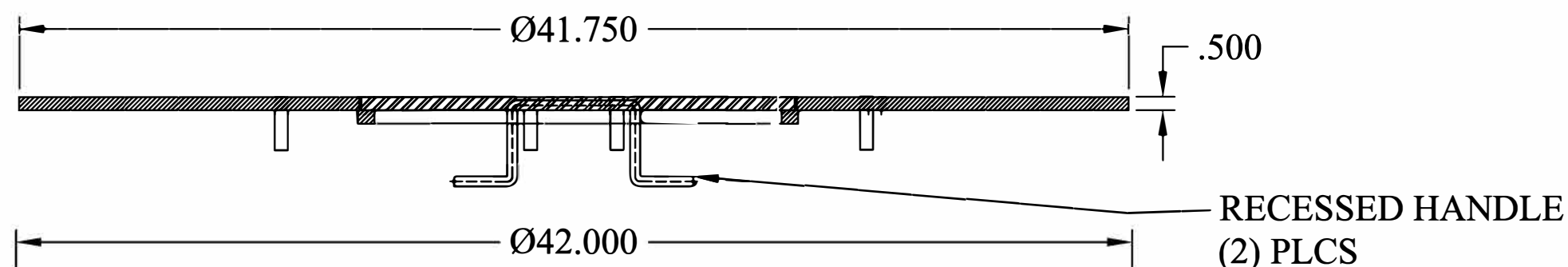

This document is proprietary and confidential. No part of this document may be disclosed in any manner to a third party without the prior written consent of Fairfield Industries, Inc.

DO NOT SCALE DRAWING

UNLESS OTHERWISE SPECIFIED, DIMENSIONS ARE IN INCHES.

TOLERANCES ON ANGLES: ± 1°
 FRACTIONAL: ± 1/64
 2-PLACE DECIMALS: ± 0.05
 3-PLACE DECIMALS: ± 0.005

THIRD ANGLE PROJECTION

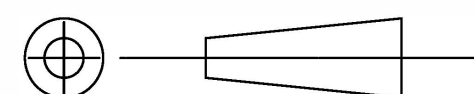

FAIRFIELD INDUSTRIES, INC

4483 CHOPPEE ROAD, GEORGETOWN SC 29440

PHONE: 843-461-3894 FAX: 843-461-3907

DESCRIPTION

421- HD

SIZE C	SCALE NTS	DWG. NO D101118-2	C.REV -	REV 1
DRAWN BY D. NETTLES		DATE 10/11/18	SHT 1 OF 1	