

FEATURES:

- STEEL T-FRAME CONSTRUCTION
- REINFORCED DIAMOND PLATE STEEL COVERS WITH H-20 TRUCK LOAD RATING
- 14GA. SKIRT
- TWO (2) RECESSED HANDLES LIFT HANDLES
- TWO (2) 16" DIAMOND PLATE COVER
- ALL STEEL COATED WITH A RUST PREVENTATIVE PAINT
- CHANNEL-STYLE CONCRETE ANCHORS

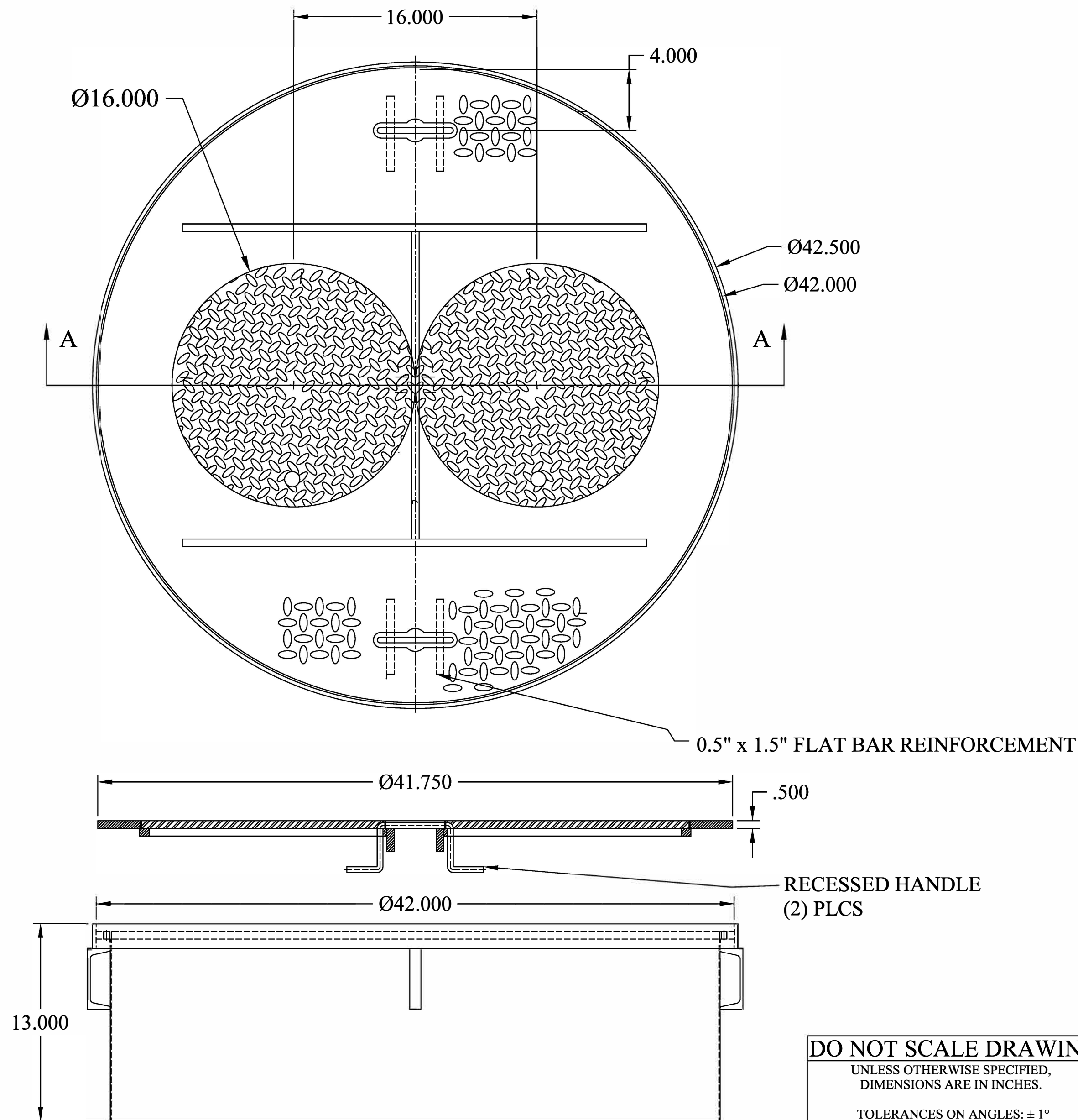

This document is proprietary and confidential. No part of this document may be disclosed in any manner to a third party without the prior written consent of Fairfield Industries

DO NOT SCALE DRAWING

UNLESS OTHERWISE SPECIFIED, DIMENSIONS ARE IN INCHES.

TOLERANCES ON ANGLES: ± 1°
 FRACTIONAL: ± 1/64
 2-PLACE DECIMALS: ± 0.05
 3-PLACE DECIMALS: ± 0.005

THIRD ANGLE PROJECTION

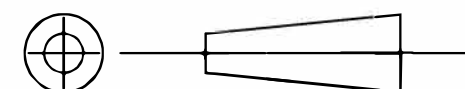

FAIRFIELD INDUSTRIES, INC

4483 CHOPPEE ROAD, GEORGETOWN SC 29440

PHONE: 843-461-3894

FAX: 843-461-3907

DESCRIPTION

422- HD

SIZE

SCALE

NTS

DWG. NO

D030619-2

C.REV

REV

DRAWN BY

D. NETTLES

DATE 12/10/20

SHT

1 OF 1