

0.5" THICK REINFORCED
DIAMOND PLATE COVER

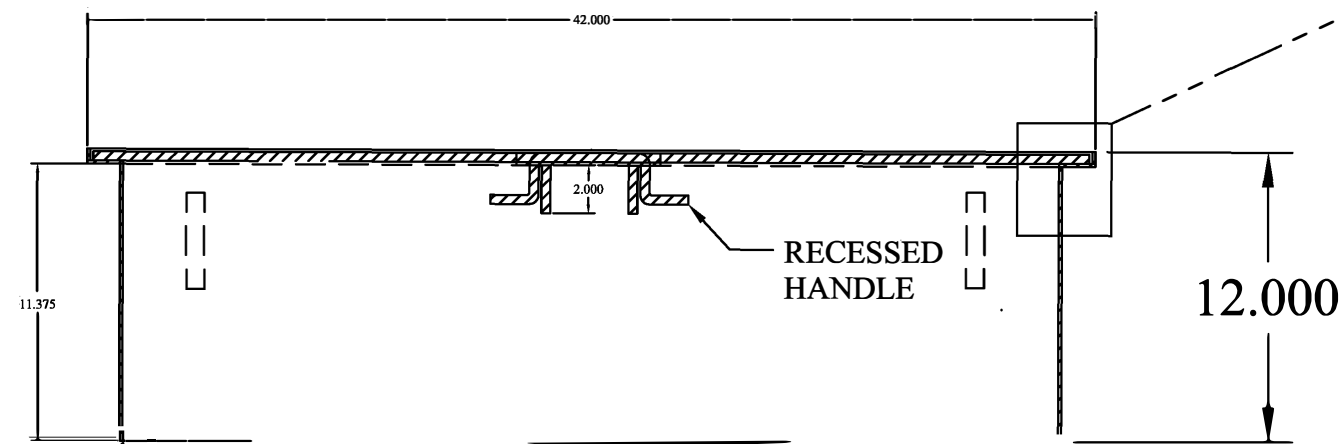

SECTION A-A

OPEN BOTTOM

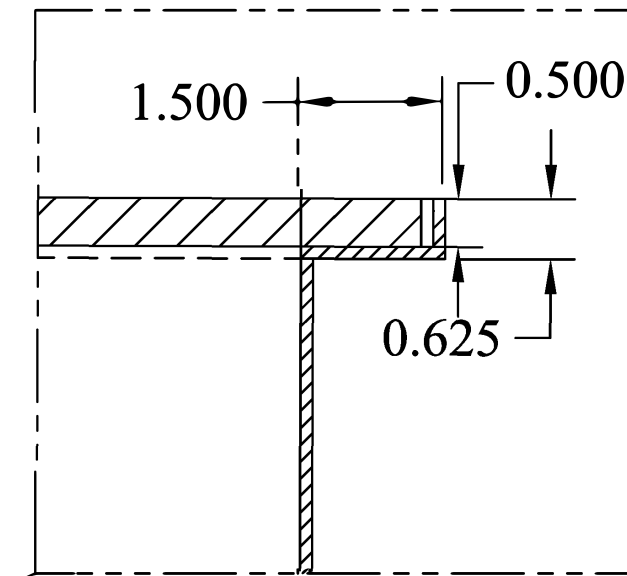
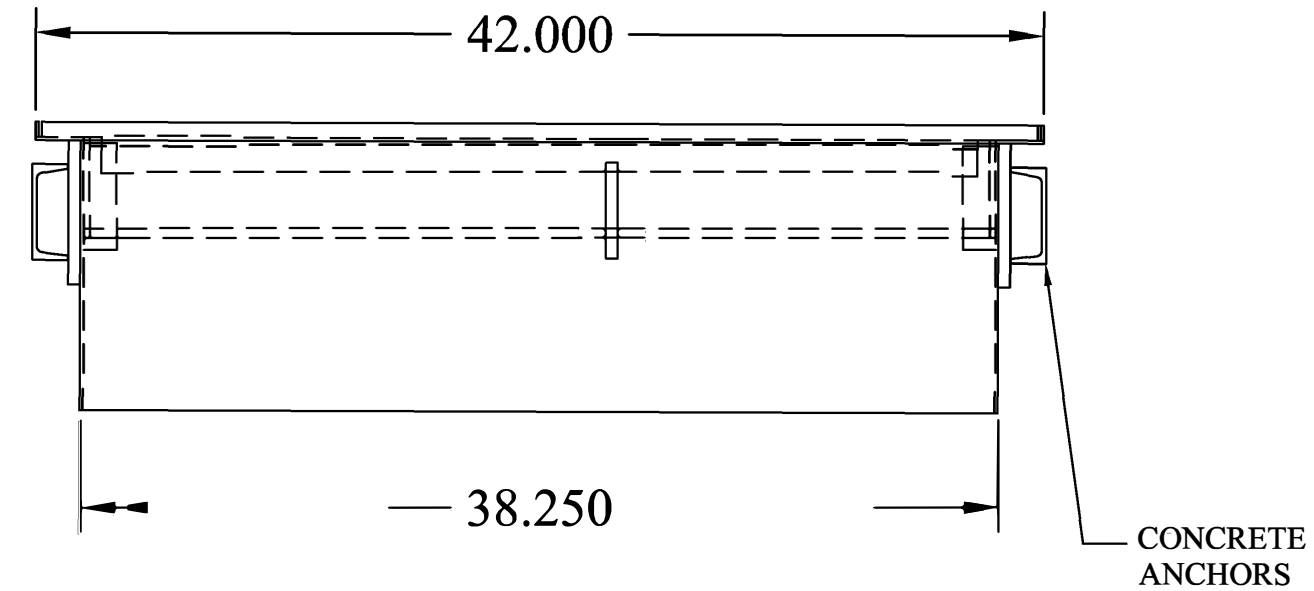

FEATURES

- 0.5" THICK DIAMOND PLATE REINFORCED COVER H-20 TRUCK LOAD RATING, RECESSED HANDLES
- 11GAUGE TOP FRAME AND SKIRT, ALL WELDED CONSTRUCTION
- CHANNEL-STYLE CONCRETE ANCHORS
- ALL STEEL COATED WITH A RUST PREVENTIVE PAINT
- MADE IN USA

This document is proprietary and confidential. No part of this document may be disclosed in any manner to a third party without the prior written consent of Fairfield Industries

DO NOT SCALE DRAWING
UNLESS OTHERWISE SPECIED
DIMENSIONS ARE IN INCHES.
TOLERANCES ON ANGLES: ± 1°
FRACTIONAL: ± 1/16
2-PLACE DECIMALS: ± 0.062
3-PLACE DECIMAL: ± 0.032

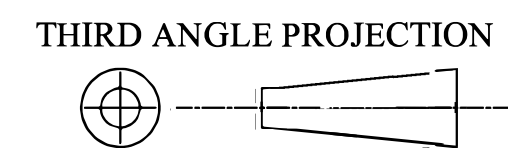

FAIRFIELD INDUSTRIES, INC			
4483 CHOPPEE ROAD, GEORGETOWN SC 29440			
PHONE: 843-461-3894		FAX: 843-461-3907	
DESCRIPTION 42S			
SIZE C	SCALE NTS	DWG.NO. D102319-4	REV. 1
DRAWN BY D. NETTLES		DATE 10/23/19	
SHT. 1 OF 3			