

# 48" WATER TIGHT

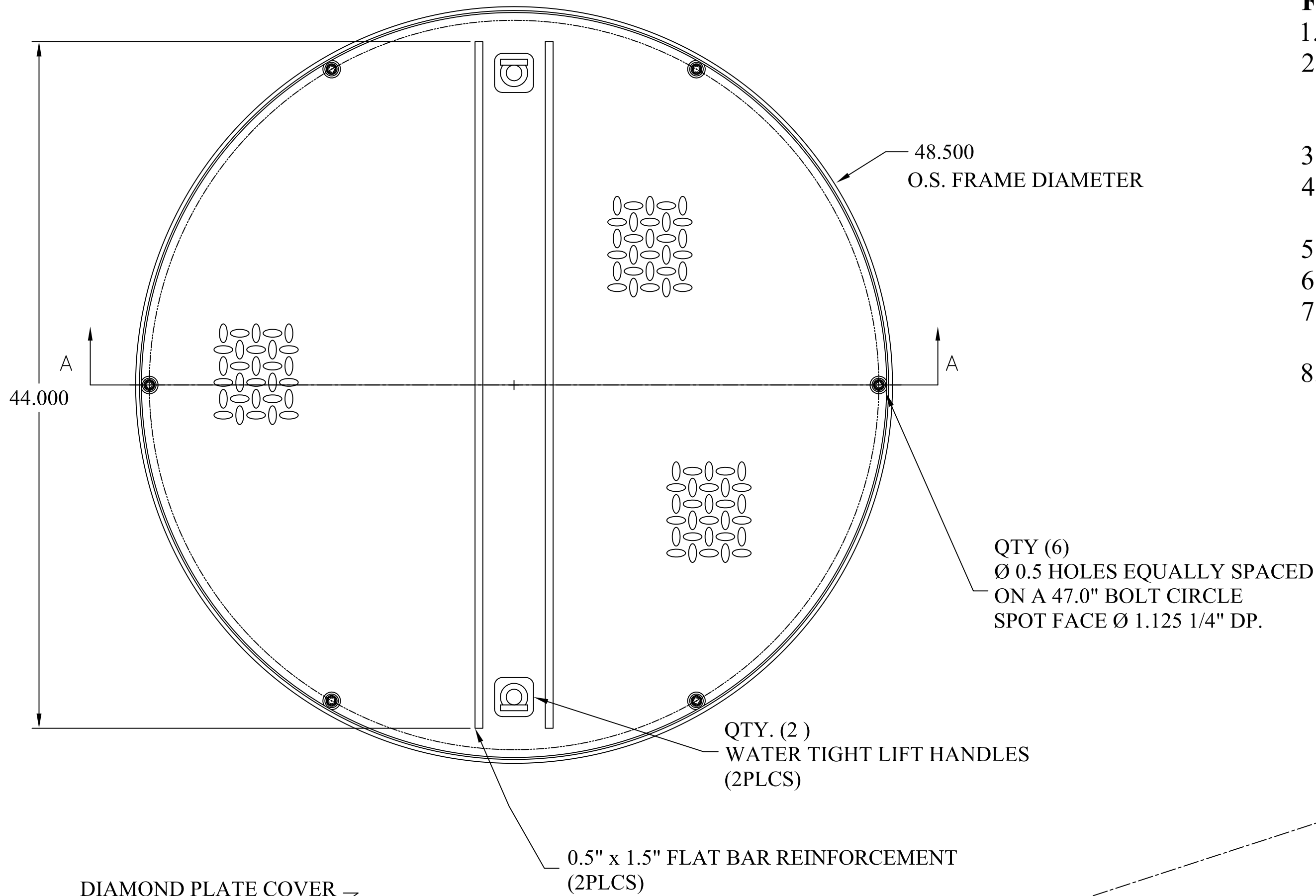

## FEATURES:

1. STEEL T-FRAME CONSTRUCTION
2. REINFORCED 0.5" THK. DIAMOND PLATE STEEL COVER WITH H-20 TRUCK LOAD RATING
3. 14GA. CARBON STEEL SKIRT
4. SIX (6) RECESSED STAINLESS STEEL HEX BOLTS
5. 1/8" BUNA-N GASKET
6. TWO (2) WATER TIGHT LIFT HANDLES
7. ALL STEEL COATED WITH A RUST PREVENTATIVE PAINT
8. CHANNEL-STYLE CONCRETE ANCHORS

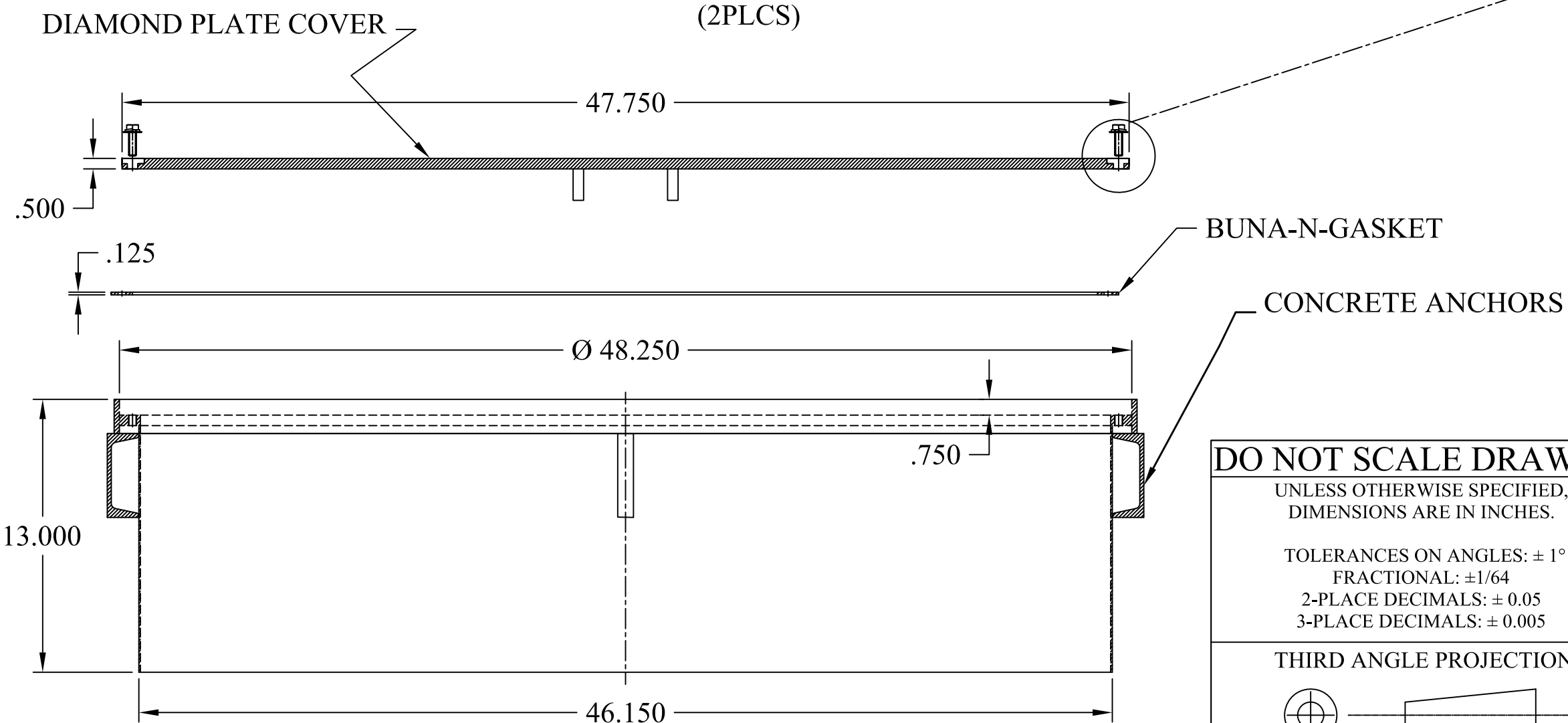
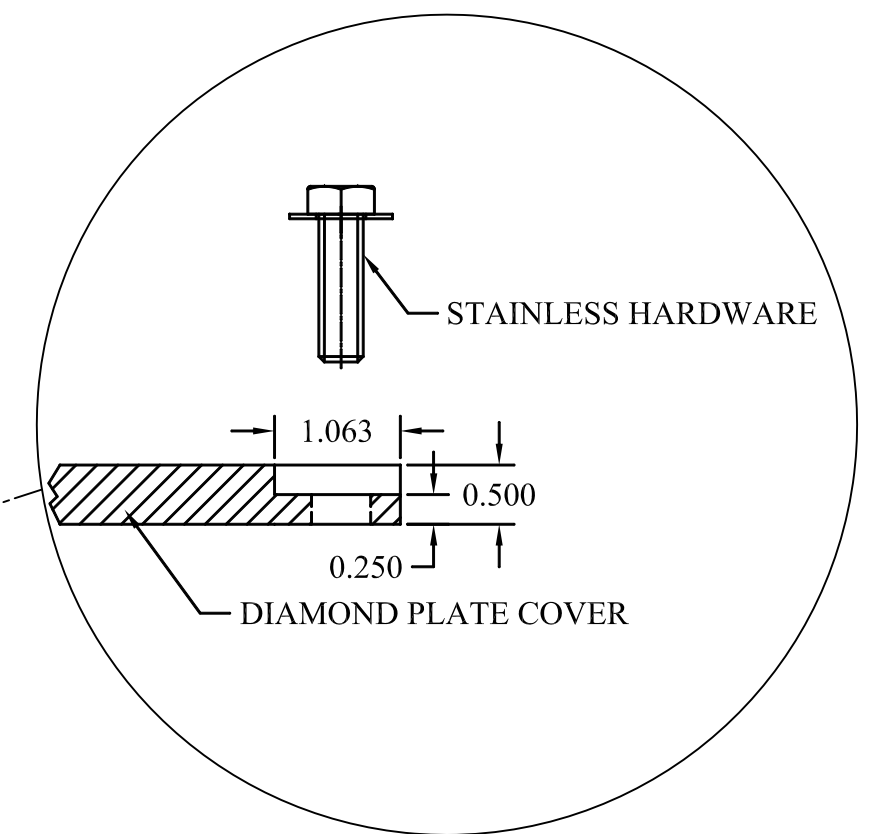

This document is proprietary and confidential. No part of this document may be disclosed in any manner to a third party without the prior written consent of Fairfield Industries

### DO NOT SCALE DRAWING

UNLESS OTHERWISE SPECIFIED, DIMENSIONS ARE IN INCHES.

TOLERANCES ON ANGLES:  $\pm 1^\circ$   
 FRACTIONAL:  $\pm 1/64$   
 2-PLACE DECIMALS:  $\pm 0.05$   
 3-PLACE DECIMALS:  $\pm 0.005$

THIRD ANGLE PROJECTION

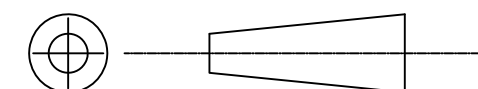

## FAIRFIELD INDUSTRIES, INC

4483 CHOPPEE ROAD, GEORGETOWN SC 29440

PHONE: 843-461-3894

FAX: 843-461-3907

DESCRIPTION

480WT

SIZE

SCALE

NTS

DWG. NO

D080519-3

C.REV

REV

-

1

DRAWN BY

D NETTLES

DATE

08/05/19

SHT

1 OF 1