

**FEATURES:**

- STEEL T-FRAME CONSTRUCTION
- REINFORCED 0.5" THK. DIAMOND PLATE STEEL COVER WITH H-20 TRUCK LOAD RATING
- 14 GA. CARBON STEEL SKIRT
- TWO (2) RECESSED STEEL HANDLES
- 16.0" DIAMETER 0.5" THK. DIAMOND PLATE INSP. COVER
- ALL STEEL COATED WITH A RUST PREVENTATIVE PAINT
- CHANNEL-STYLE CONCRETE ANCHORS
- MADE IN USA

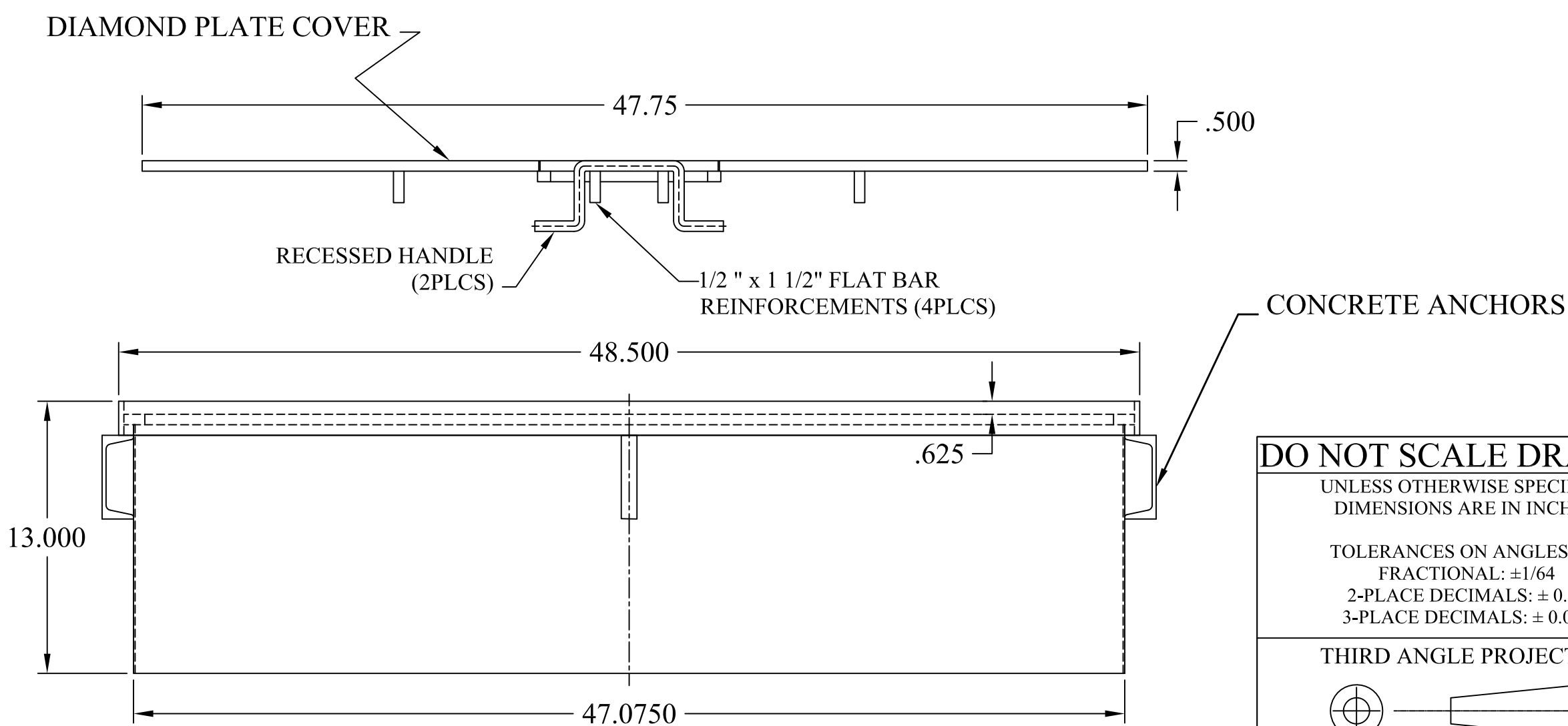

This document is proprietary and confidential. No part of this document may be disclosed in any manner to a third party without the prior written consent of Fairfield Industries

**DO NOT SCALE DRAWING**  
 UNLESS OTHERWISE SPECIFIED, DIMENSIONS ARE IN INCHES.  
 TOLERANCES ON ANGLES: ± 1°  
 FRACTIONAL: ± 1/64  
 2-PLACE DECIMALS: ± 0.05  
 3-PLACE DECIMALS: ± 0.005  
 THIRD ANGLE PROJECTION

<b>FAIRFIELD INDUSTRIES, INC</b>					
4483 CHOPPEE ROAD, GEORGETOWN SC 29440					
PHONE: 843-461-3894			FAX: 843-461-3907		
DESCRIPTION 481-HD					
SIZE C	SCALE NTS	DWG. NO D050218-2	C.REV -	REV 1	
DRAWN BY D NETTLES		DATE 05/02/18	SHT 1 OF 1		