

ABOVE GROUND SPILL CONTAINER-SS

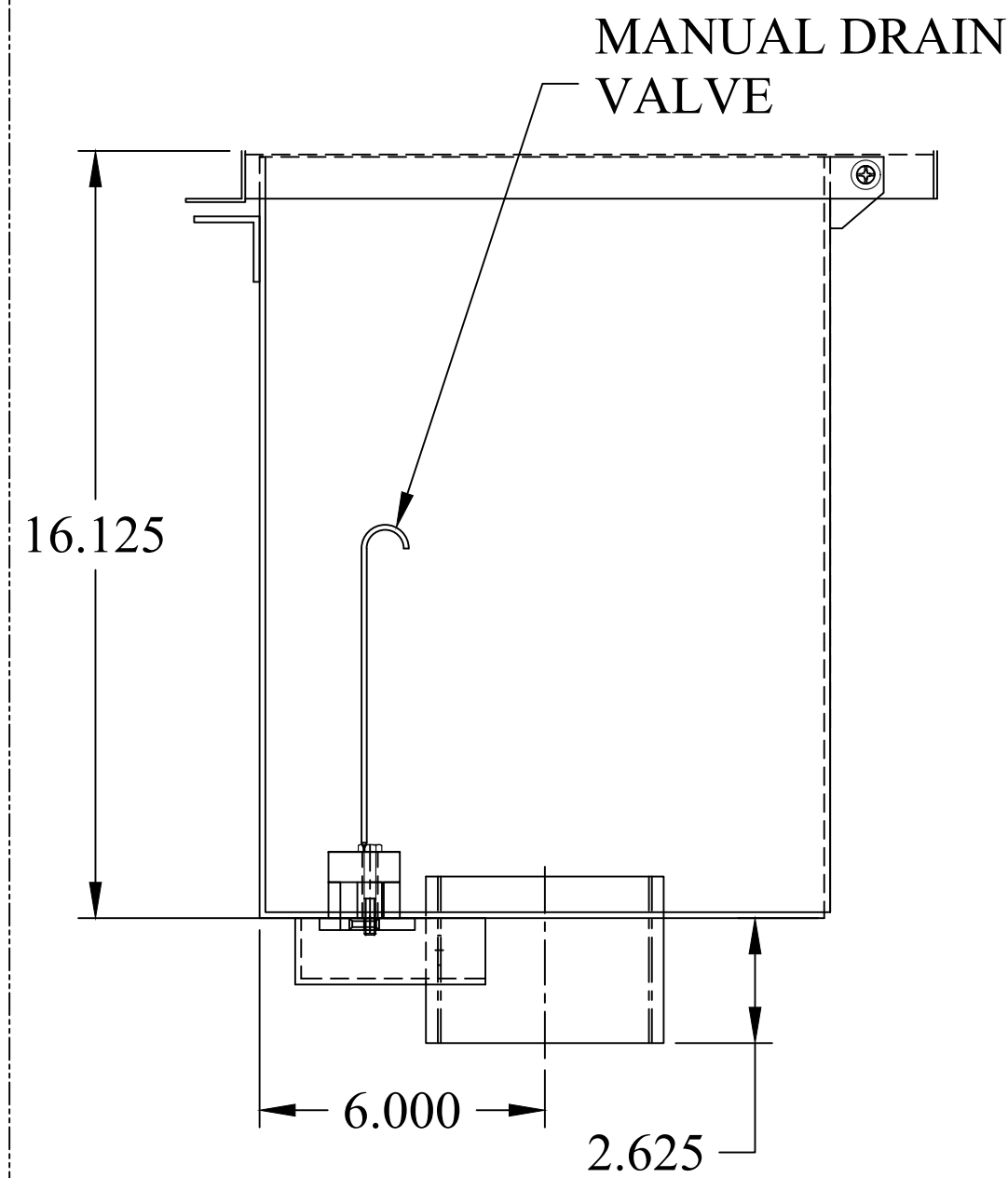

FEATURES:

- MATERIAL: HEAVY GAUGE STAINLESS STEEL
- LOCKABLE FLIP-TOP COVER THAT HOLDS ITSELF IN THE UPRIGHT POSITION
- 4.0" NPT COUPLING
- 10 GALLON CAPACITY
- MANUAL DRAIN VALVE
- MADE IN USA

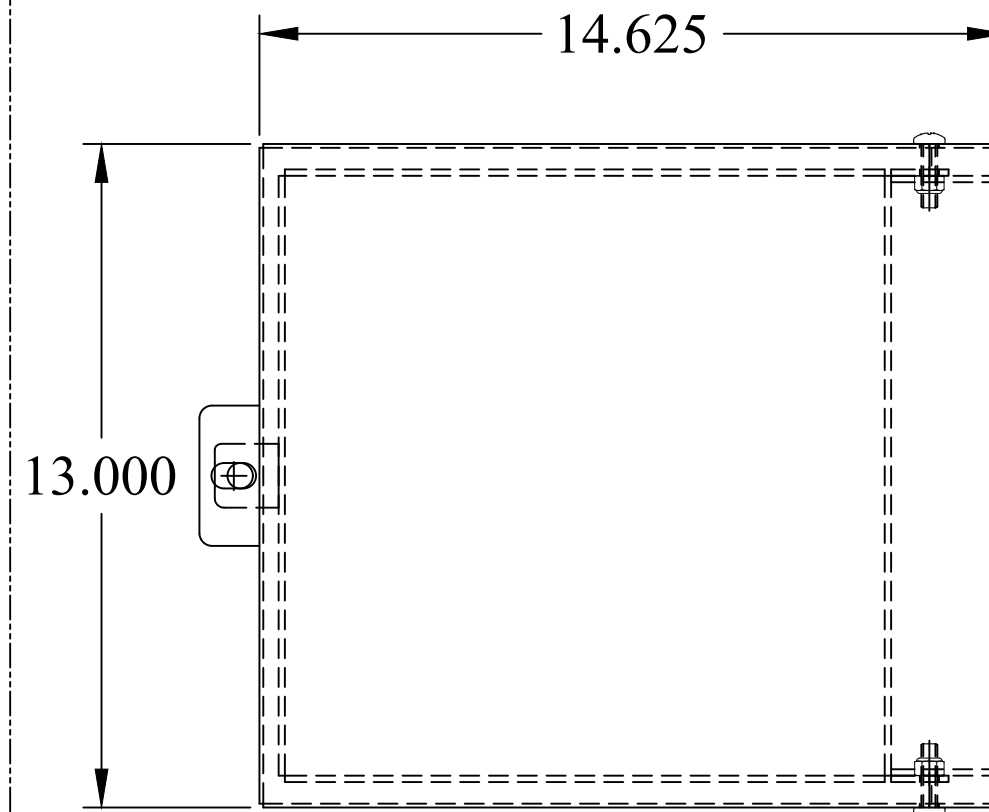
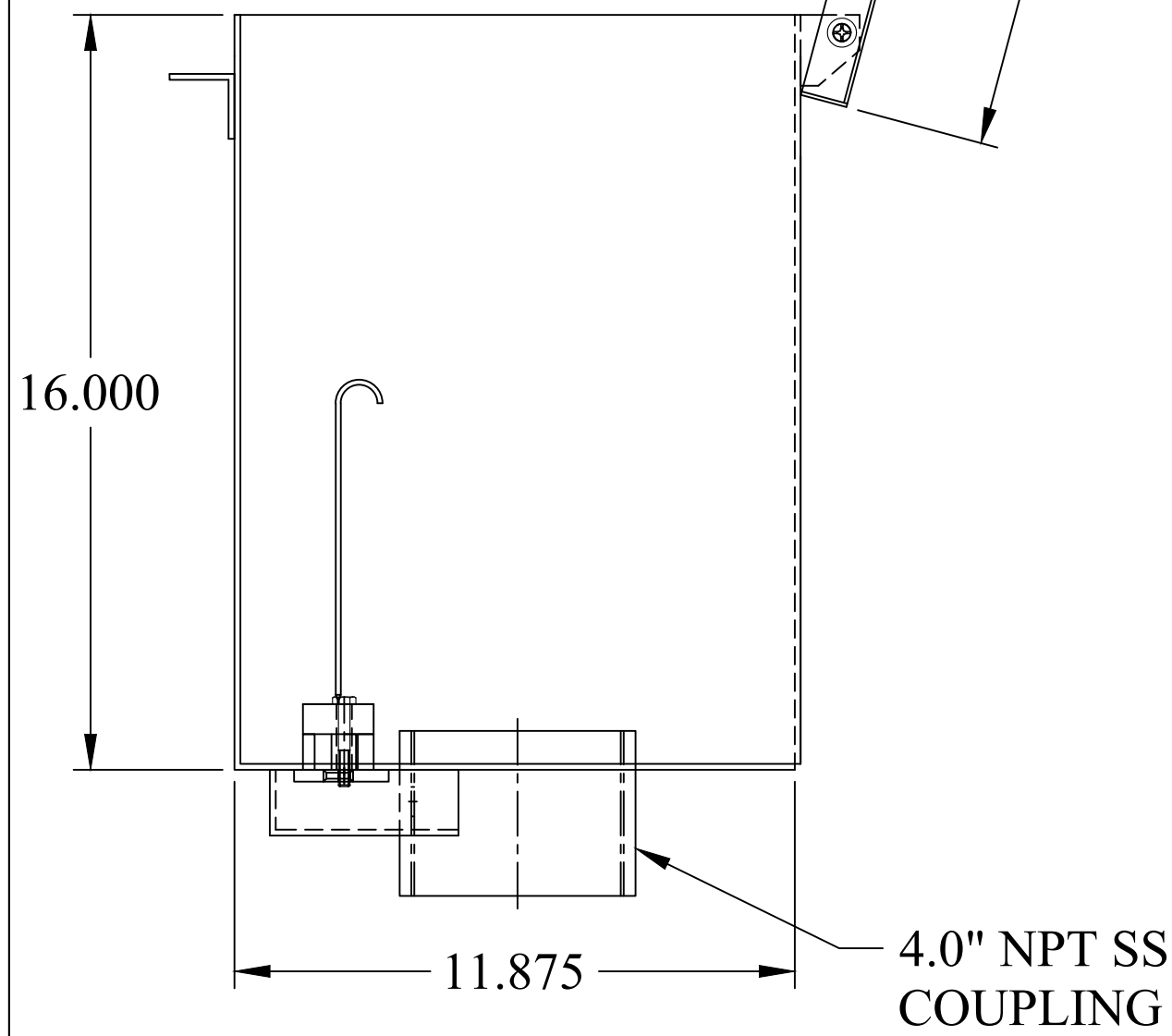
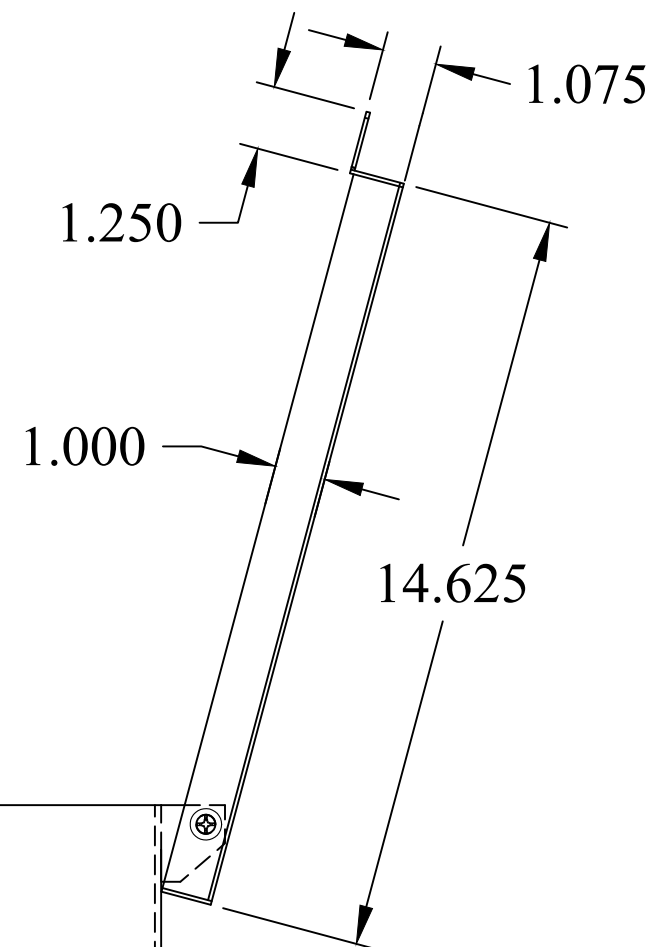
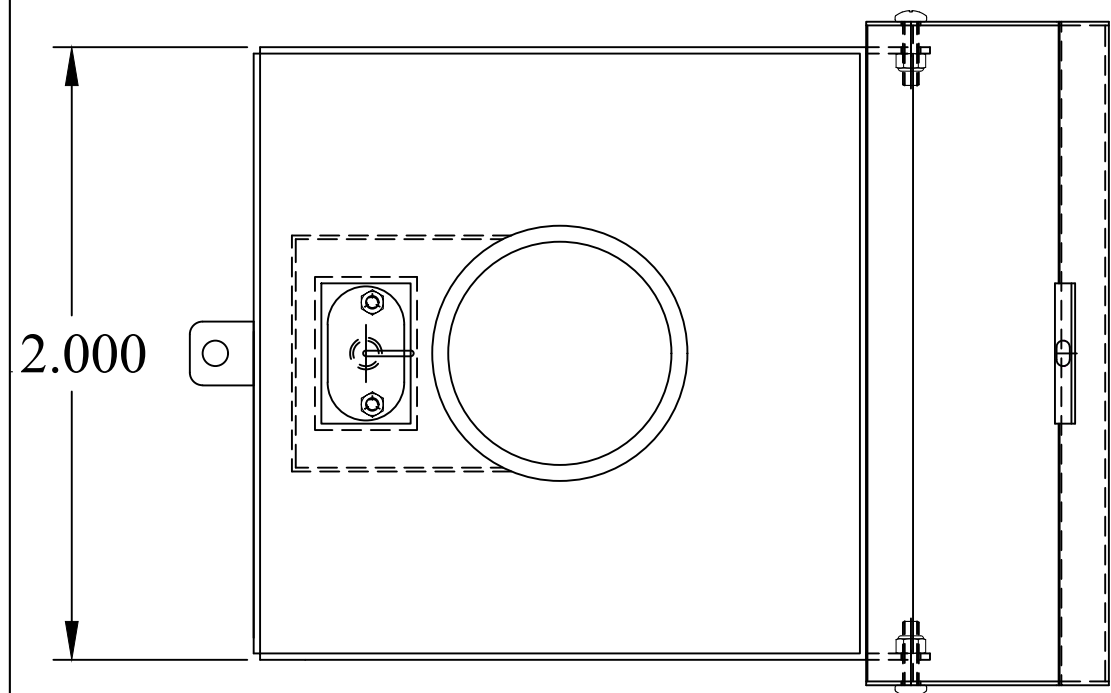
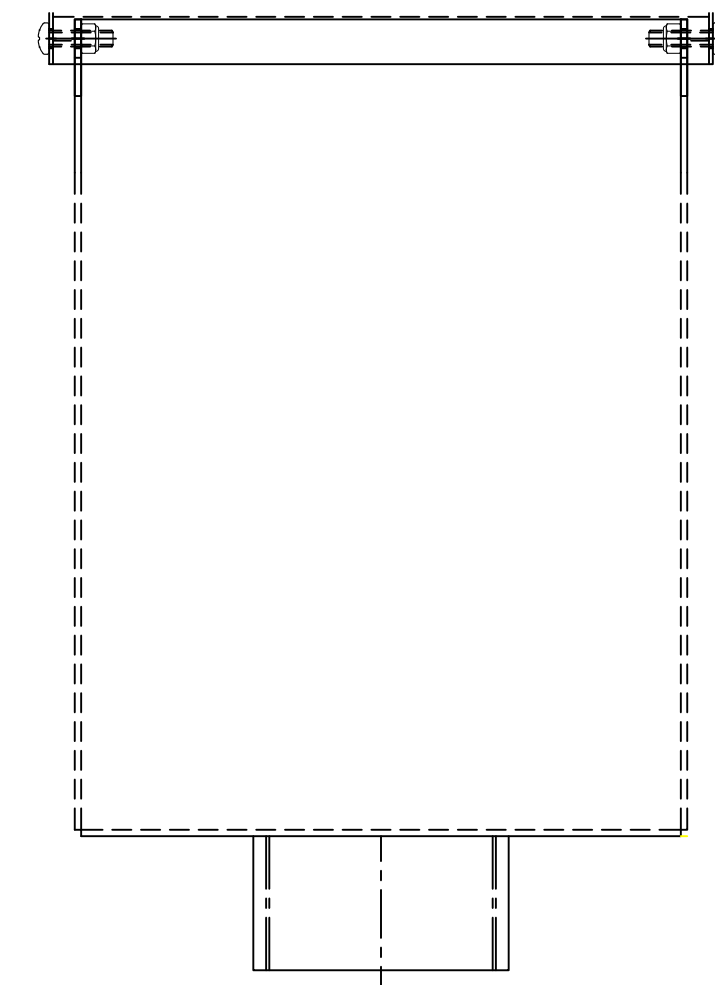

This document is proprietary and confidential. No part of this document may be disclosed in any manner to a third party without the prior written consent of Fairfield Industries

DO NOT SCALE DRAWING

UNLESS OTHERWISE SPECIFIED, DIMENSIONS ARE IN INCHES.

TOLERANCES ON ANGLES: $\pm 1^\circ$
 FRACTIONAL: $\pm 1/64$
 2-PLACE DECIMALS: ± 0.05
 3-PLACE DECIMALS: ± 0.005

THIRD ANGLE PROJECTION

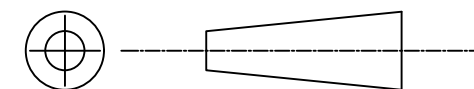

FAIRFIELD INDUSTRIES, INC

4483 CHOPPEE ROAD, GEORGETOWN SC 29440

PHONE: 843-461-3894 FAX: 843-461-3907

DESCRIPTION

AGSC-10-4"

SIZE	SCALE	DWG. NO	C.REV	REV
C	NTS	D081021-3	-	1
DRAWN BY		DATE	SHT	
D. NETTLES		08/10/21	1 OF 1	