

FEATURES:

- MATERIAL: HEAVY GAUGE STAINLESS STEEL
- LOCKABLE FLIP-TOP COVER THAT HOLDS ITSELF IN THE UPRIGHT POSITION
- WELDED ON WALL MOUNT BRACKETS
- 4.0" NPT COUPLING
- 20 GALLON CAPACITY
- MANUAL DRAIN VALVE
- MADE IN USA

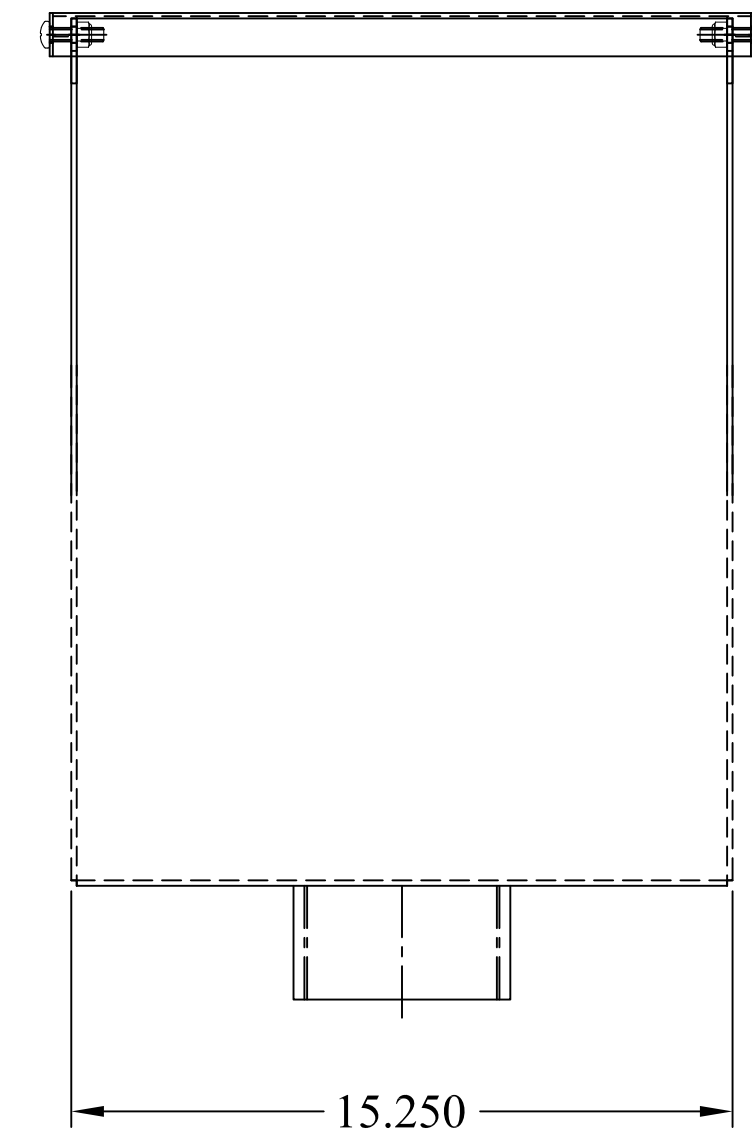
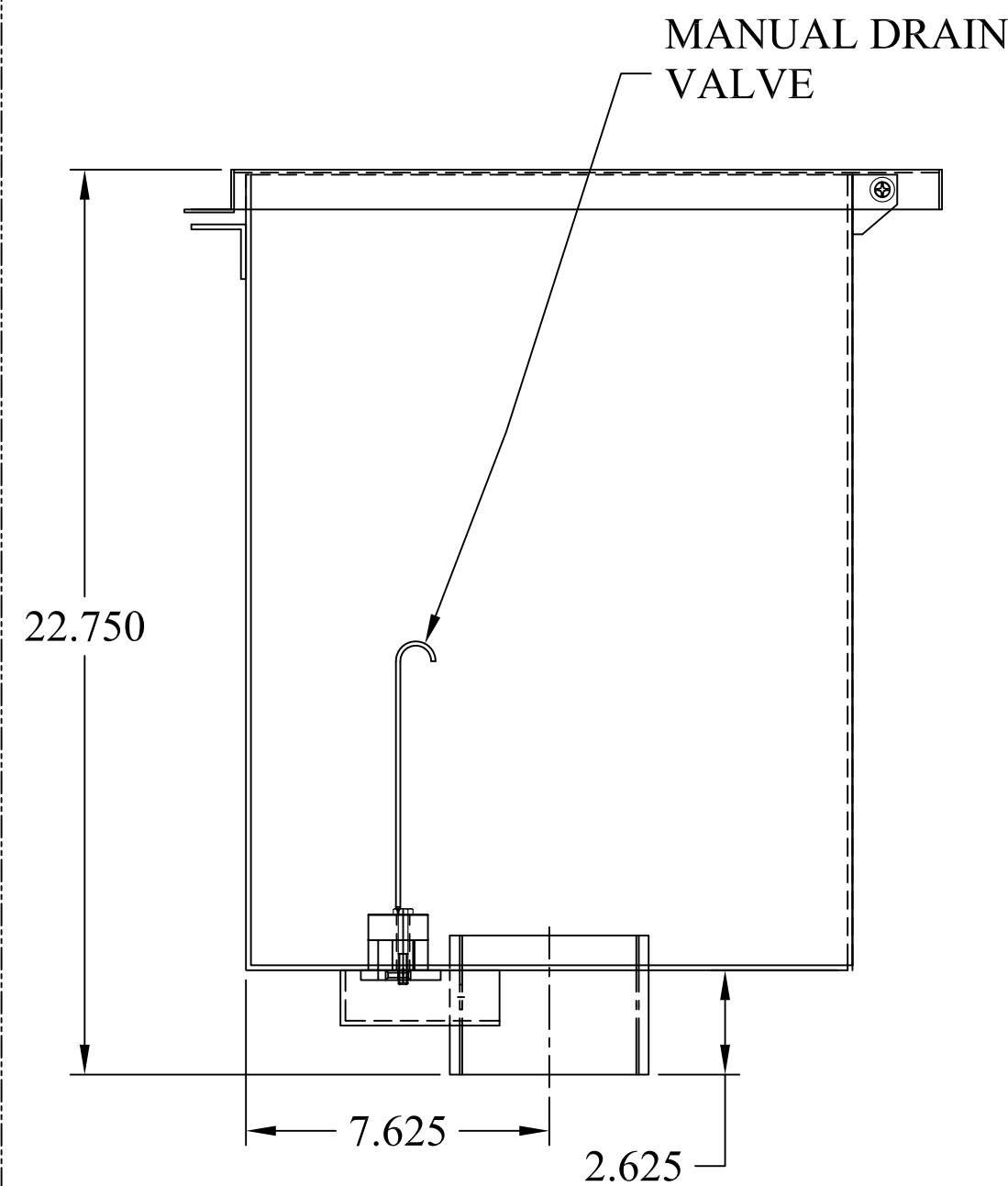
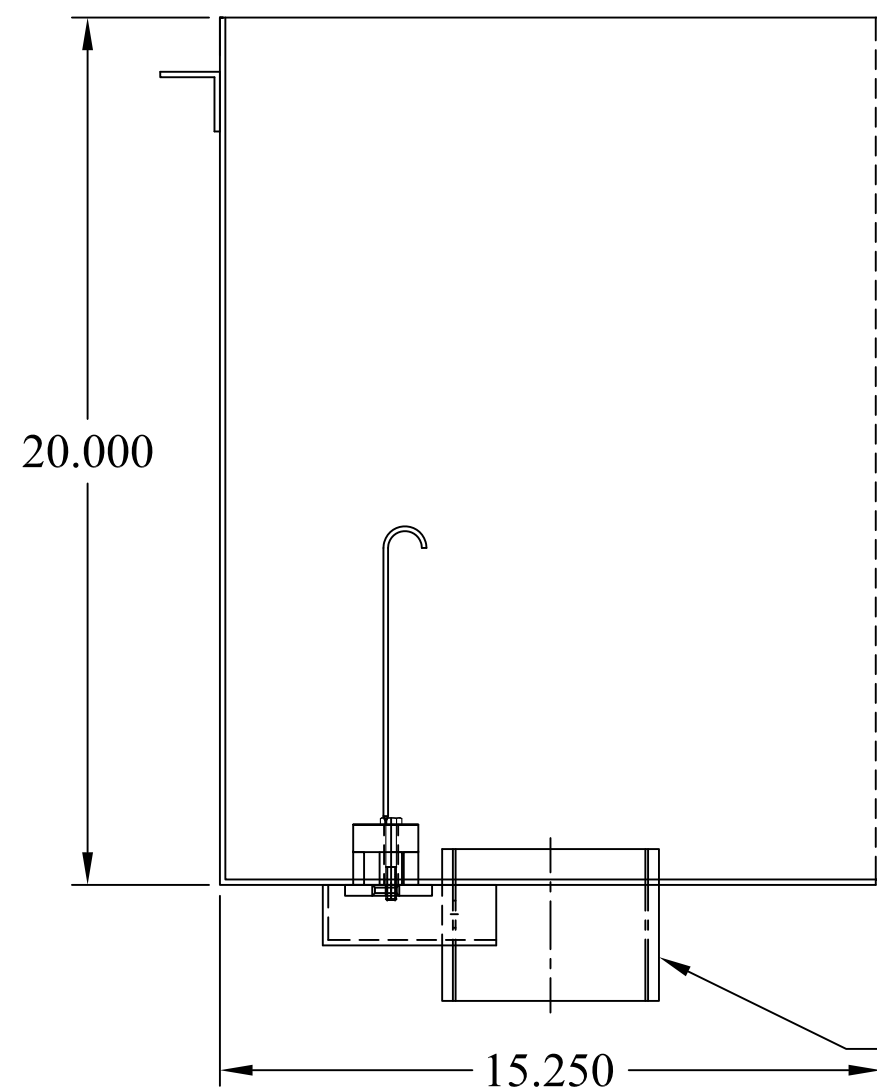
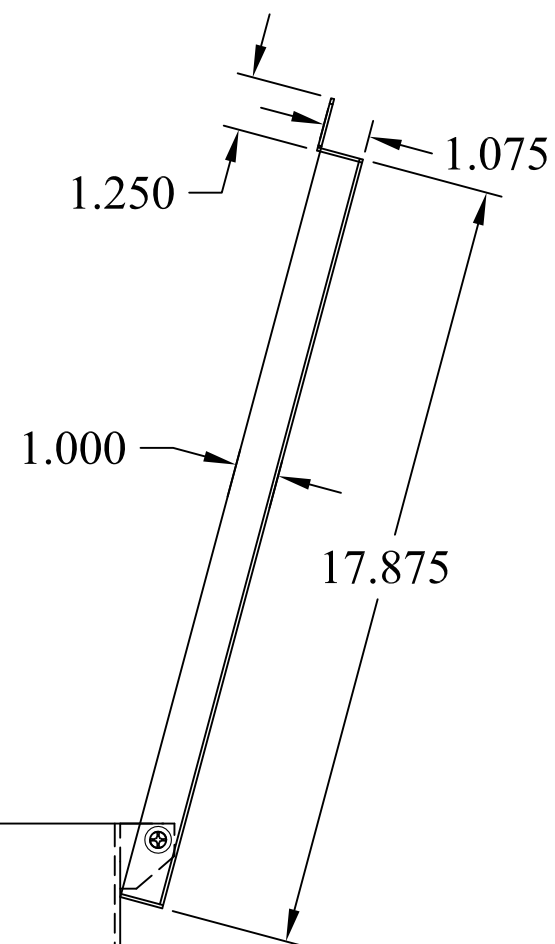

4.0" NPT SS COUPLING

DO NOT SCALE DRAWING

UNLESS OTHERWISE SPECIFIED, DIMENSIONS ARE IN INCHES.

TOLERANCES ON ANGLES: $\pm 1^\circ$
 FRACTIONAL: $\pm 1/64$
 2-PLACE DECIMALS: ± 0.05
 3-PLACE DECIMALS: ± 0.005

THIRD ANGLE PROJECTION

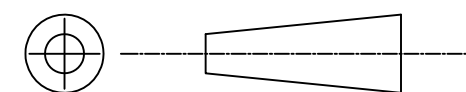

FAIRFIELD INDUSTRIES, INC

4483 CHOPPEE ROAD, GEORGETOWN SC 29440
 PHONE: 843-461-3894 FAX: 843-461-3907

DESCRIPTION
AGSC-20-4"

SIZE C	SCALE NTS	DWG. NO D091619-1	C.REV -	REV 1
------------------	---------------------	-----------------------------	-------------------	-----------------

DRAWN BY D. NETTLES	DATE 09/16/19	SHT 1 OF 1
-------------------------------	-------------------------	----------------------

This document is proprietary and confidential. No part of this document may be disclosed in any manner to a third party without the prior written consent of Fairfield Industries