

# ABOVE GROUND SPILL CONTAINER-SS

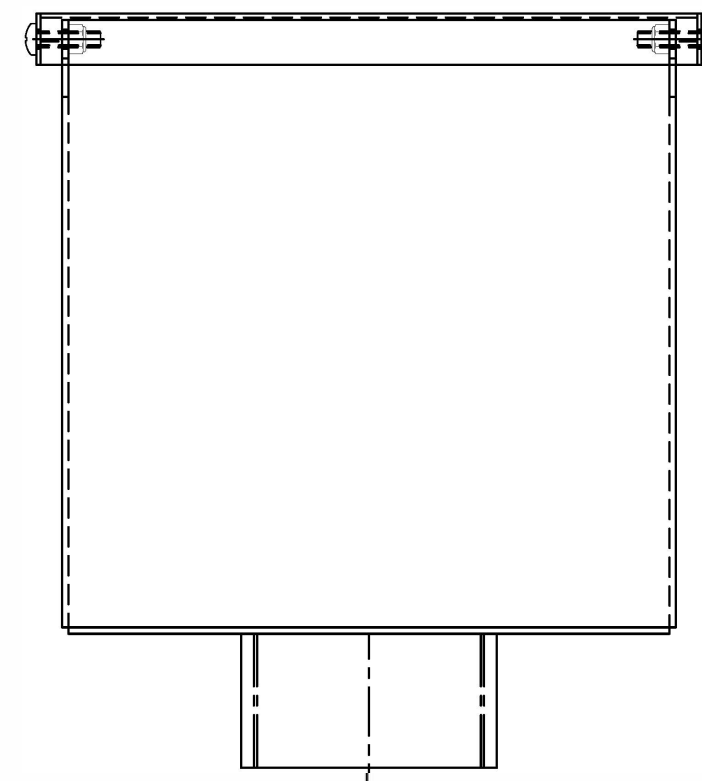
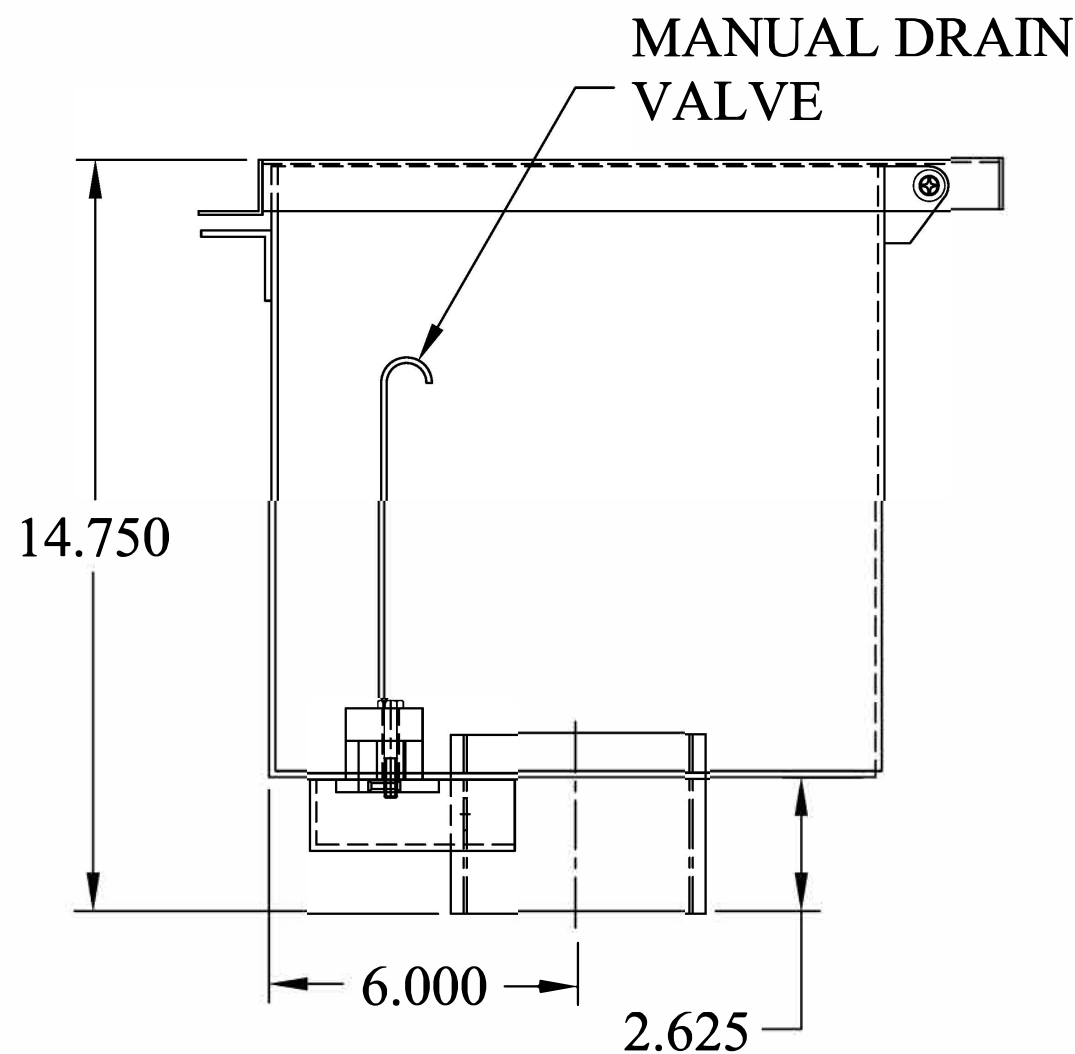
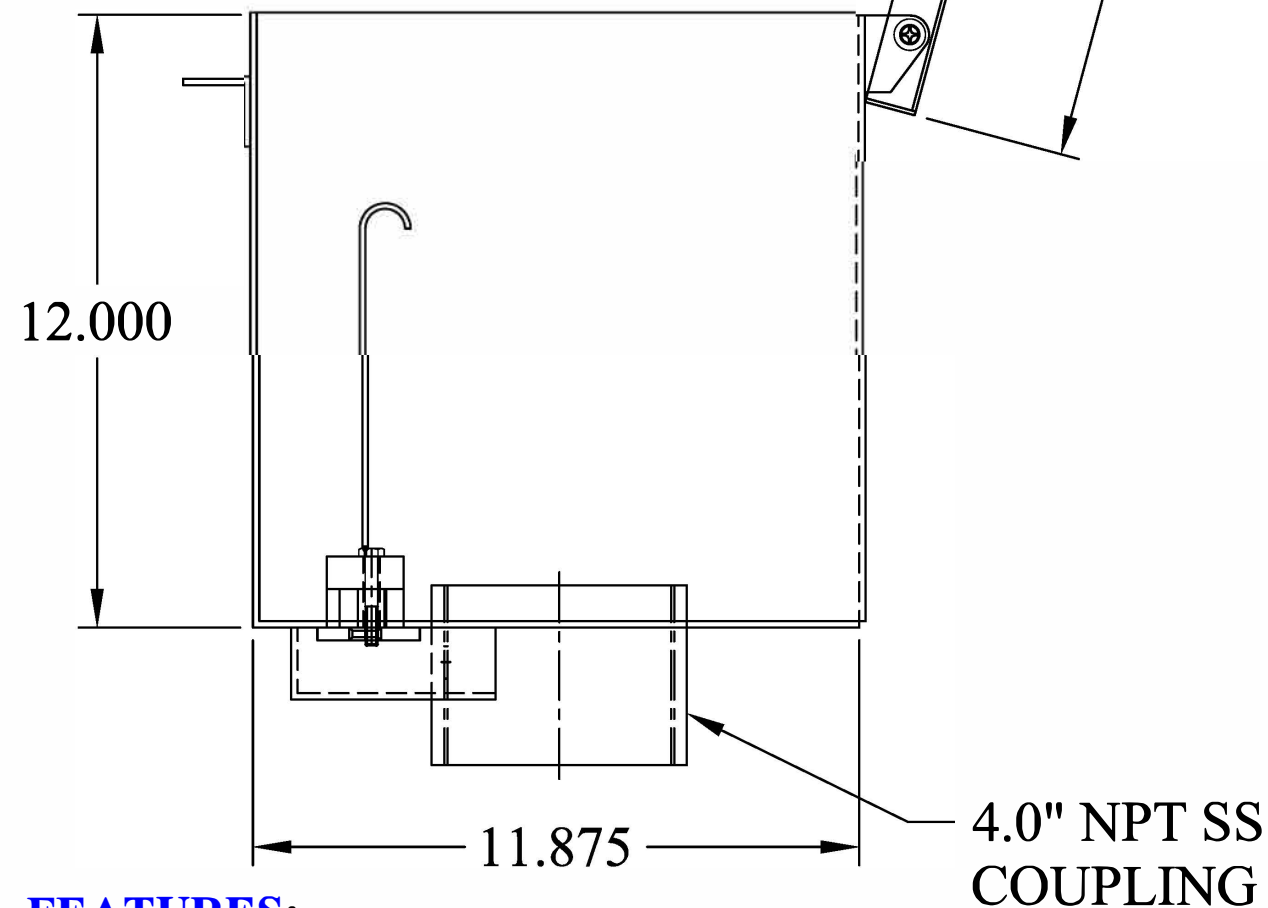
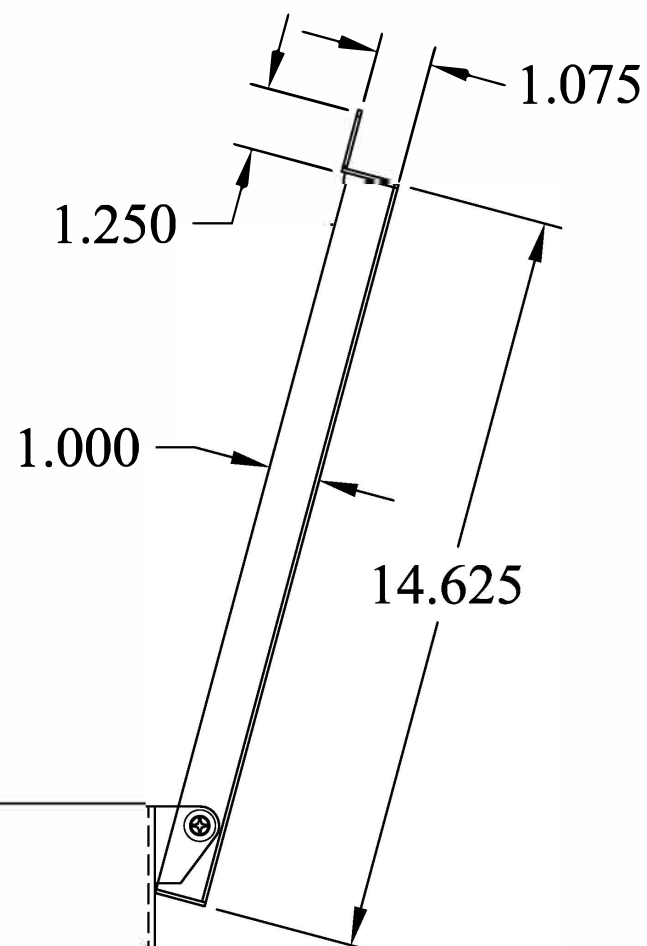
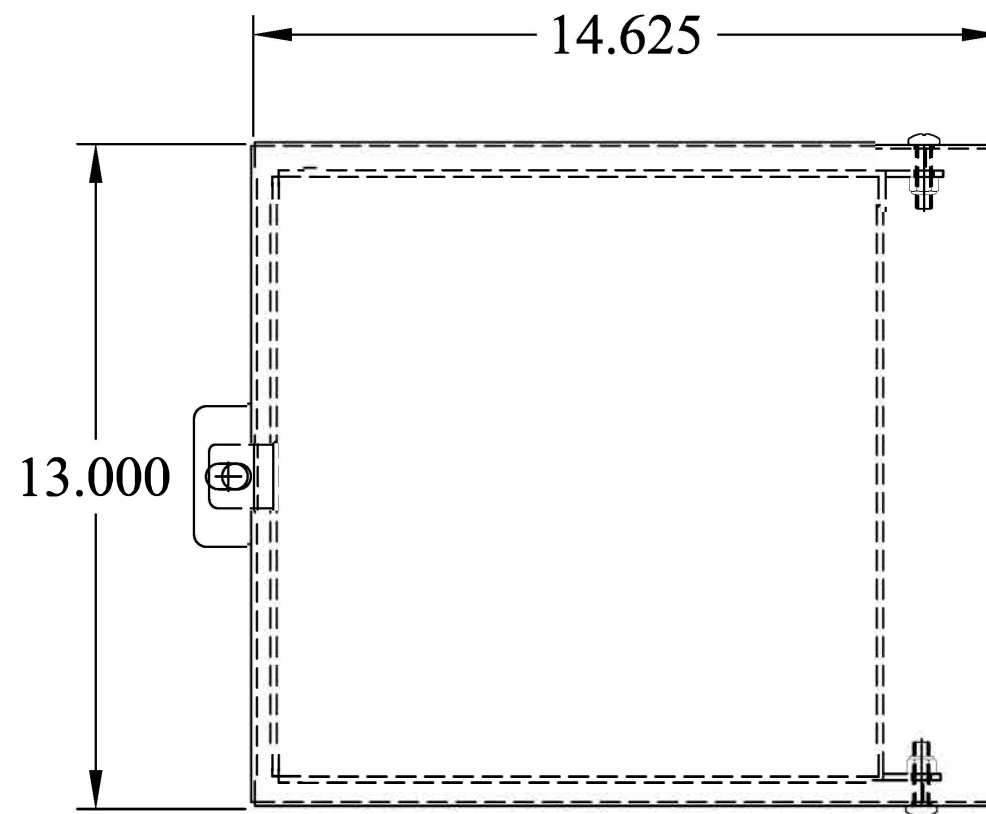
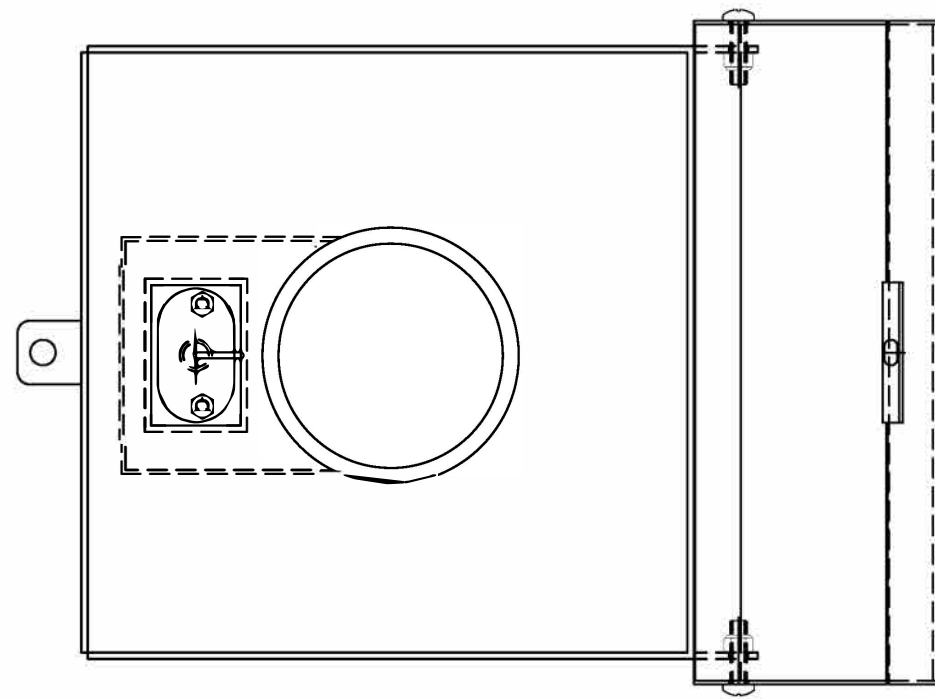

AGSC SERIES				
MODEL	SIZE	CAP.	S/S	C/S
AGSC-3	2, 3, 4"	3 Gal.	X	
AGSC-5	2, 3, 4"	5 Gal.	X	
AGSC-7	2, 3, 4"	7 Gal.	X	
AGSC-7C	2, 3, 4"	7 Gal.		X
AGSC-10	2, 3, 4"	10 Gal.	X	
AGSC-15	2, 3, 4"	15 Gal.	X	
AGSC-20	2, 3, 4"	20 Gal.	X	
OPTIONS				
MODEL#	DESCRIPTION			
AGSC-WMB	WALL MOUNT BRACKETS			
AGSC-FMB	FLOOR MOUNT			
AGSC-LEGS	LEGS			

This document is proprietary and confidential. No part of this document may be disclosed in any manner to a third party without the prior written consent of Fairfield Industries

## FEATURES:

- MATERIAL: HEAVY GAUGE STAINLESS STEEL
- LOCKABLE FLIP-TOP COVER THAT HOLDS ITSELF IN THE UPRIGHT POSITION
- WELDED ON WALL MOUNT BRACKETS
- NPT COUPLING
- 7 GALLON CAPACITY
- MANUAL DRAIN VALVE
- MADE IN USA

## DO NOT SCALE DRAWING

UNLESS OTHERWISE SPECIFIED, DIMENSIONS ARE IN INCHES.

TOLERANCES ON ANGLES:  $\pm 1^\circ$   
 FRACTIONAL:  $\pm 1/64$   
 2-PLACE DECIMALS:  $\pm 0.05$   
 3-PLACE DECIMALS:  $\pm 0.005$

## THIRD ANGLE PROJECTION

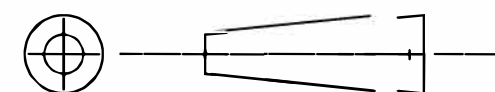

## FAIRFIELD INDUSTRIES, INC

4483 CHOPPEE ROAD, GEORGETOWN SC 29440

PHONE: 843-461-3894 FAX: 843-461-3907

DESCRIPTION

## AGSC SERIES

SIZE <b>C</b>	SCALE <b>NTS</b>	DWG. NO <b>D031721-7</b>	C.REV <b>-</b>	REV <b>1</b>
DRAWN BY <b>D. NETTLES</b>		DATE <b>03/17/21</b>	SHT <b>1 OF 1</b>	