

FEATURES:

- HEAVY GAUGE CARBON STEEL ENCLOSURE, ALL WELDED CONSTRUCTION
- 14 GAUGE CARBON STEEL LOCKABLE HINGED DOOR
- ONE (1) 2" NPT REAR OUTLET
- 10 GALLON SPILL CONTAINMENT
- HAND PUMP W/ CHECK VALVE AND SHUTOFF
- INLET CONNECTIONS W/ QUICK CONNECTORS AND DUST CAPS
- INTERNAL PRE-PLUMBED CHECK VALVES, FITTINGS AND SHUTOFF VALVES
- ONE (1) GROUND STUD
- TWO (2) MOUNTING BRACKETS (FOR 3" PIPE)
- VENT LOCATED UNDER FRONT DOOR
- POWDER COATED WHITE
- MADE IN USA

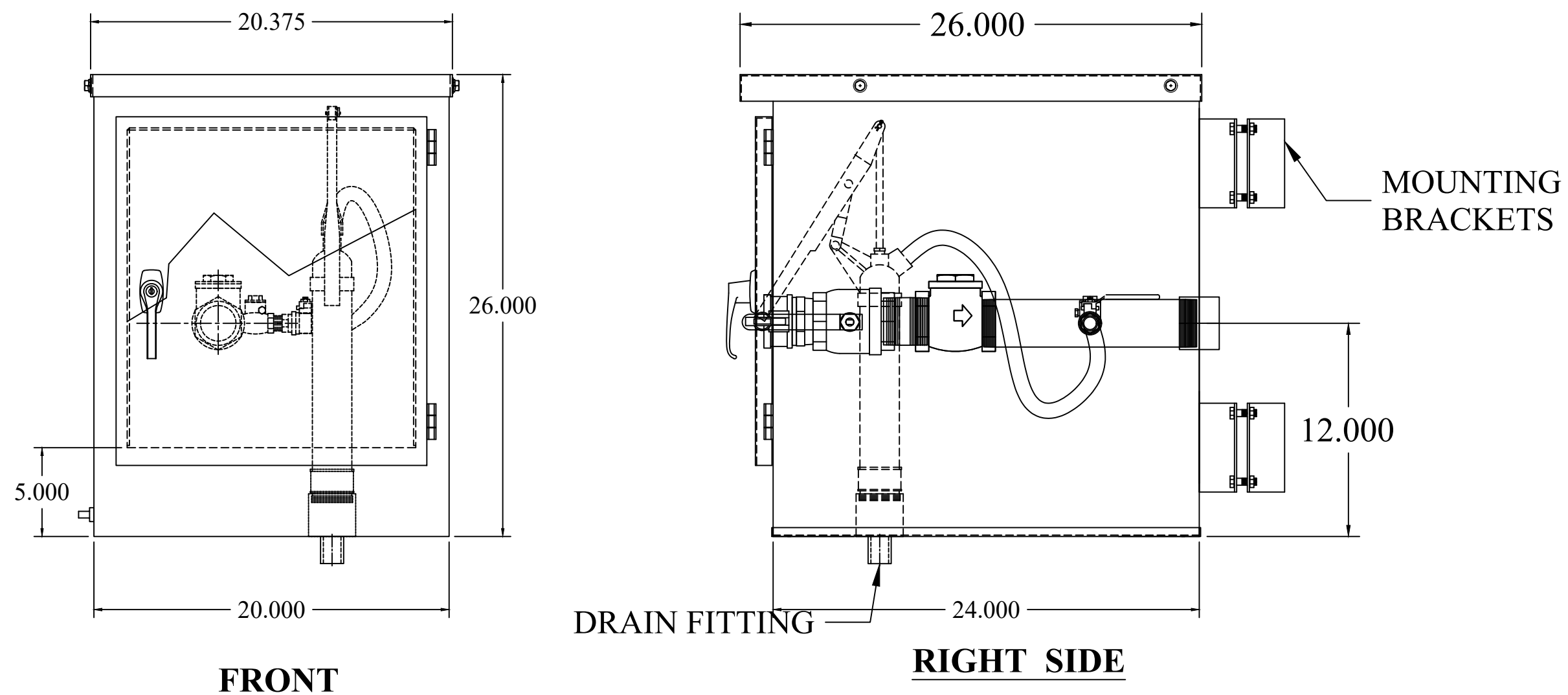

This document is proprietary and confidential. No part of this document may be disclosed in any manner to a third party without the prior written consent of Fairfield Industries

DO NOT SCALE DRAWING
 UNLESS OTHERWISE SPECIFIED, DIMENSIONS ARE IN INCHES.

TOLERANCES ON ANGLES: $\pm 1^\circ$
 FRACTIONAL: $\pm 1/64$
 2-PLACE DECIMALS: ± 0.05
 3-PLACE DECIMALS: ± 0.005

THIRD ANGLE PROJECTION

FAIRFIELD INDUSTRIES, INC					
4483 CHOPPEE ROAD, GEORGETOWN SC 29440					
PHONE: 843-461-3894			FAX: 843-461-3907		
DESCRIPTION					
ARFPC-2-R					
SIZE	SCALE	DWG. NO	C.REV	REV	
C	NTS	D052721-5	-	1	
DRAWN BY			DATE	SHT	
D. NETTLES			05/27/21	1 OF 1	