

REAR

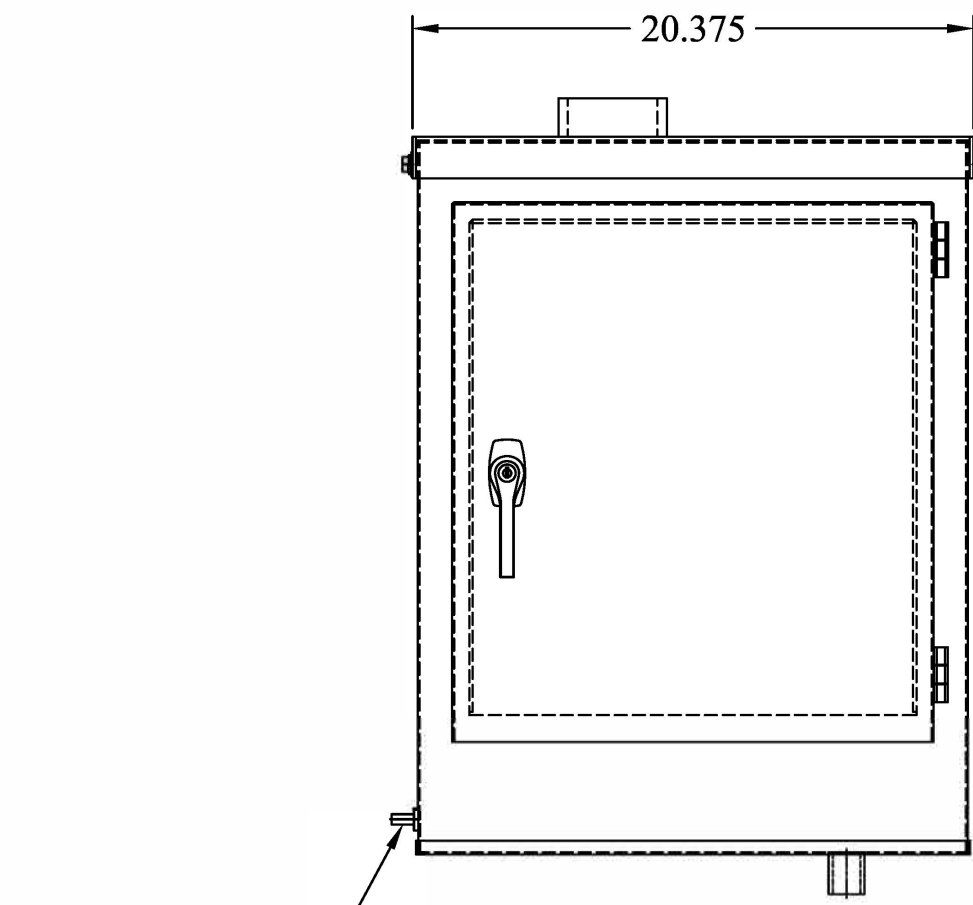

FRONT

GROUND STUD

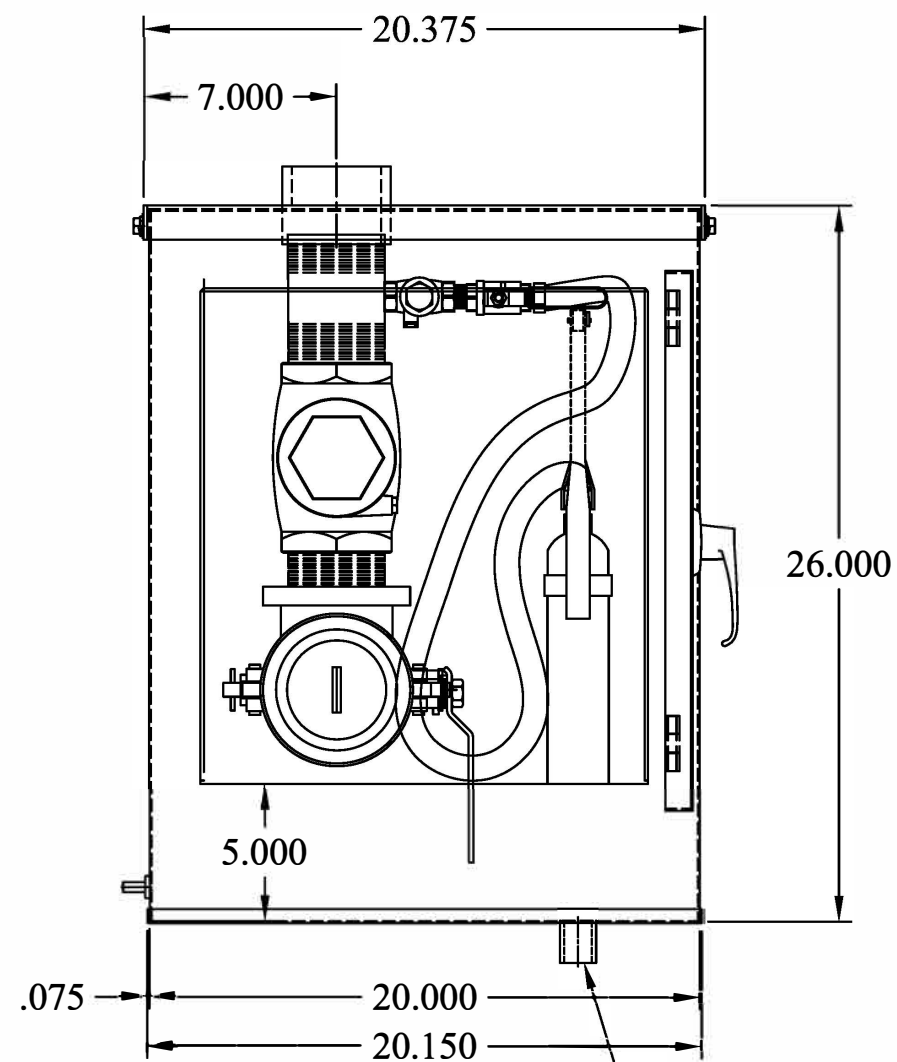

**FRONT
DOOR OPEN**

DRAIN
FITTING

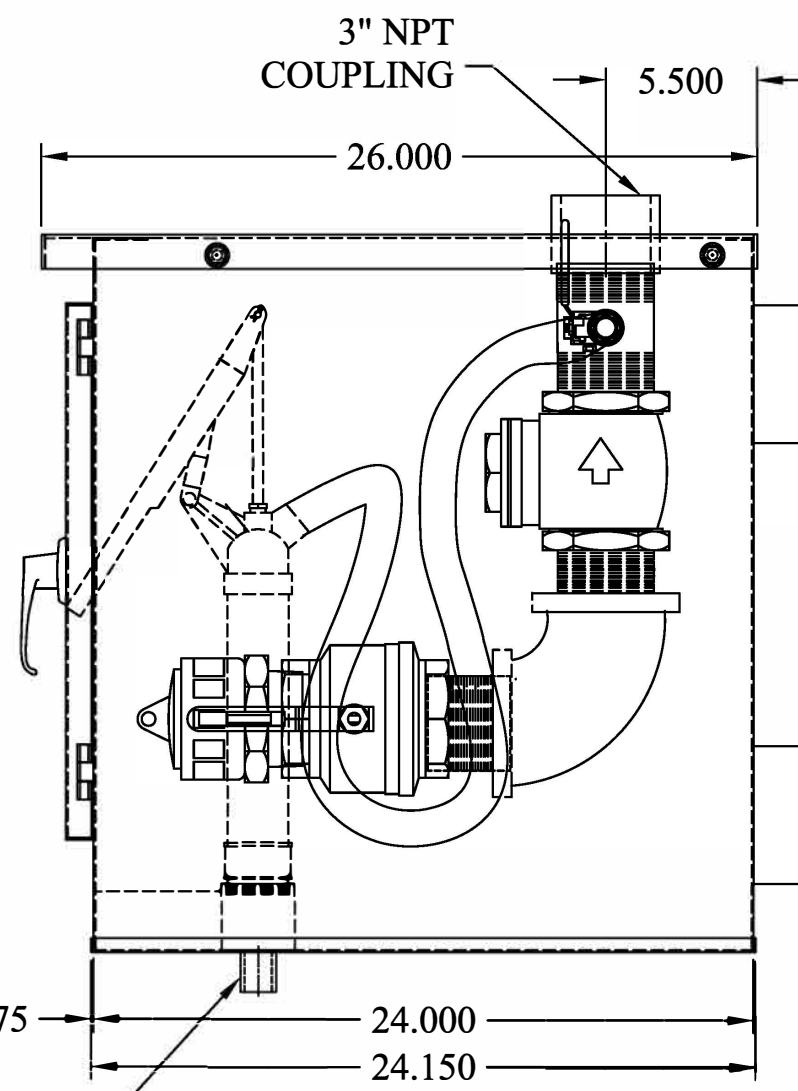

RIGHT SIDE

DRAIN
FITTING

MOUNTING
BRACKETS

FEATURES:

- DIMENSIONS: 26" HIGH X 27" DEEP X 21" WIDE
- HEAVY GAUGE CARBON STEEL ENCLOSURE, ALL WELDED CONSTRUCTION
- 14 GAUGE CARBON STEEL LOCKABLE HINDGED DOOR
- ONE (1) 3.0" NPT TOP OUTLET
- 10 GALLON SPILL CONTAINMENT
- HAND PUMP W/ CHECK VALVE AND SHUTOFF
- INLET CONNECTIONS W/ QUICK CONNECTORS AND DUST CAPS
- INTERNAL PRE-PLUMBED CHECK VALVES, FITTINGS AND SHUTOFF VALVES
- ONE (1) GROUND STUD
- TWO (2) POST MOUNT BRACKETS
- VENT LOCATED UNDER FRONT DOOR
- POWDER COATED WHITE
- MADE IN USA

This document is proprietary and confidential. No part of this document may be disclosed in any manner to a third party without the prior written consent of Fairfield Industries

DO NOT SCALE DRAWING

UNLESS OTHERWISE SPECIFIED,
DIMENSIONS ARE IN INCHES.

TOLERANCES ON ANGLES: $\pm 1^\circ$
 FRACTIONAL: $\pm 1/64$
 2-PLACE DECIMALS: ± 0.05
 3-PLACE DECIMALS: ± 0.005

THIRD ANGLE PROJECTION



FAIRFIELD INDUSTRIES, INC

4483 CHOPPEE ROAD, GEORGETOWN SC 29440

PHONE: 843-461-3894 FAX: 843-461-3907

DESCRIPTION

ARFPC-3-T

SIZE C	SCALE NTS	DWG. NO D020720-1	C.REV -	REV 1
DRAWN BY D. NETTLES		DATE 02/07/20	SHT 1 OF 1	