

FEATURES:

1. 14GA. STAINLESS STEEL SPILL CONTAINER, 15 GALLON CAPACITY.
2. HINGED, WATERPROOF SPILL CONTAINER COVER ELIMINATES WATER AND DEBRIS. LOCKABLE FOR RESTRICTED ACCESS.
3. AUTOMATIC VALVE FOR DRAINING SPILLAGE BACK INTO UNDERGROUND TANK
4. GROUND WIRE

Ø28.000

HINGED
SPILL
CONTAINER
HATCH

15 GAL. SPILL CONTAINER

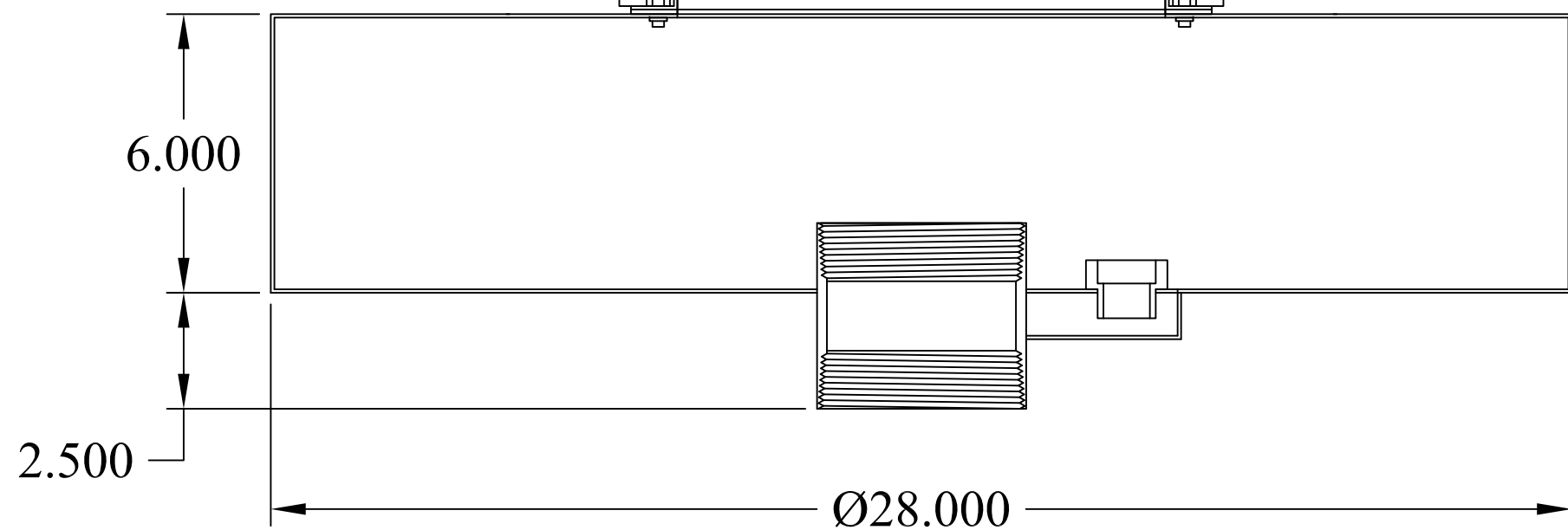

This document is proprietary and confidential. No part of this document may be disclosed in any manner to a third party without the prior written consent of Fairfield Industries

DO NOT SCALE DRAWING

UNLESS OTHERWISE SPECIFIED,
DIMENSIONS ARE IN INCHES.

TOLERANCES ON ANGLES: ± 1°
FRACTIONAL: ± 1/64
2-PLACE DECIMALS: ± 0.05
3-PLACE DECIMALS: ± 0.005

THIRD ANGLE PROJECTION

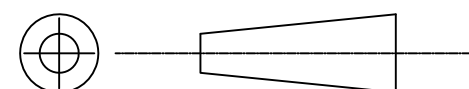

FAIRFIELD INDUSTRIES, INC

4483 CHOPPEE ROAD, GEORGETOWN SC 29440

PHONE: 843-461-3894

FAX: 843-461-3907

DESCRIPTION

BGSC-15-SB

SIZE

SCALE

NTS

DWG. NO

D110317-2

C.REV

-

REV

1

DRAWN BY

D NETTLES

DATE

11/03/17

SHT

1 OF 1