

FEATURES:

- HEAVY GAUGE 304 STAINLESS STEEL ALL WELDED CONSTRUCTION
- 15 GALLON CAPACITY.
- HINGED, WATERPROOF SPILL CONTAINER COVER ELIMINATES WATER AND DEBRIS. LOCKABLE FOR RESTRICTED ACCESS.
- MANUAL DRAIN VALVE (PUSH)
- 4" NPT COUPLING

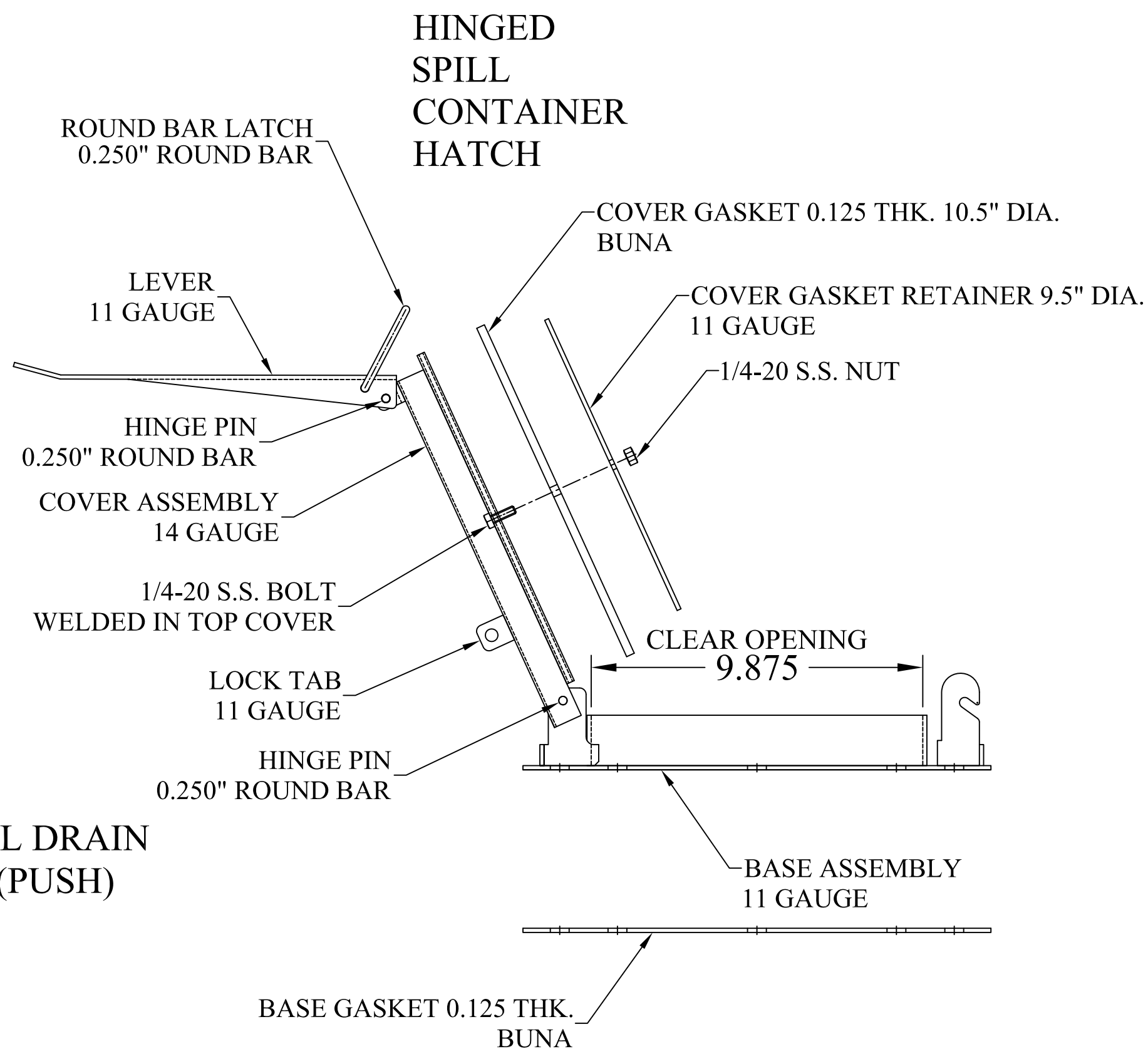
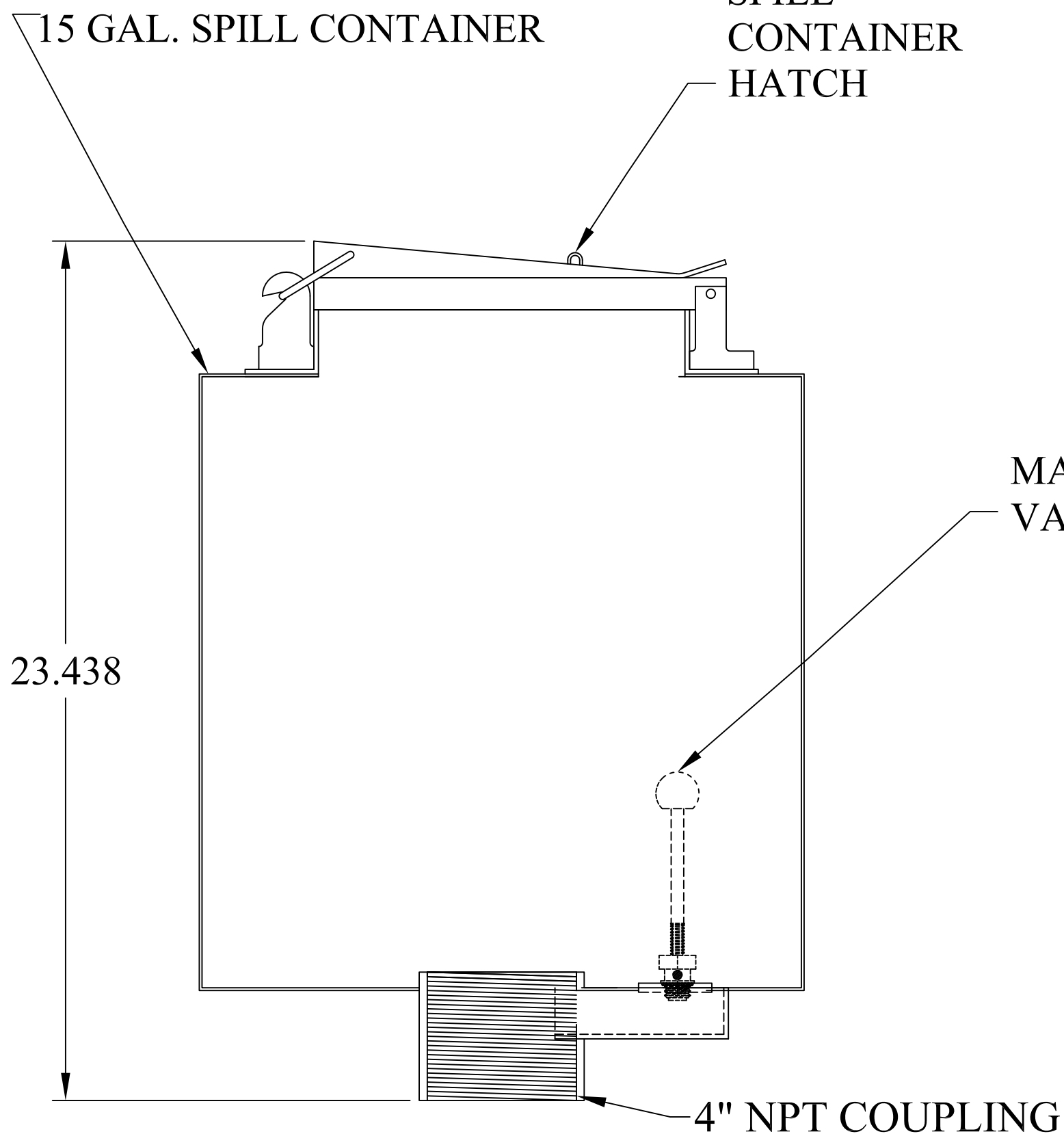
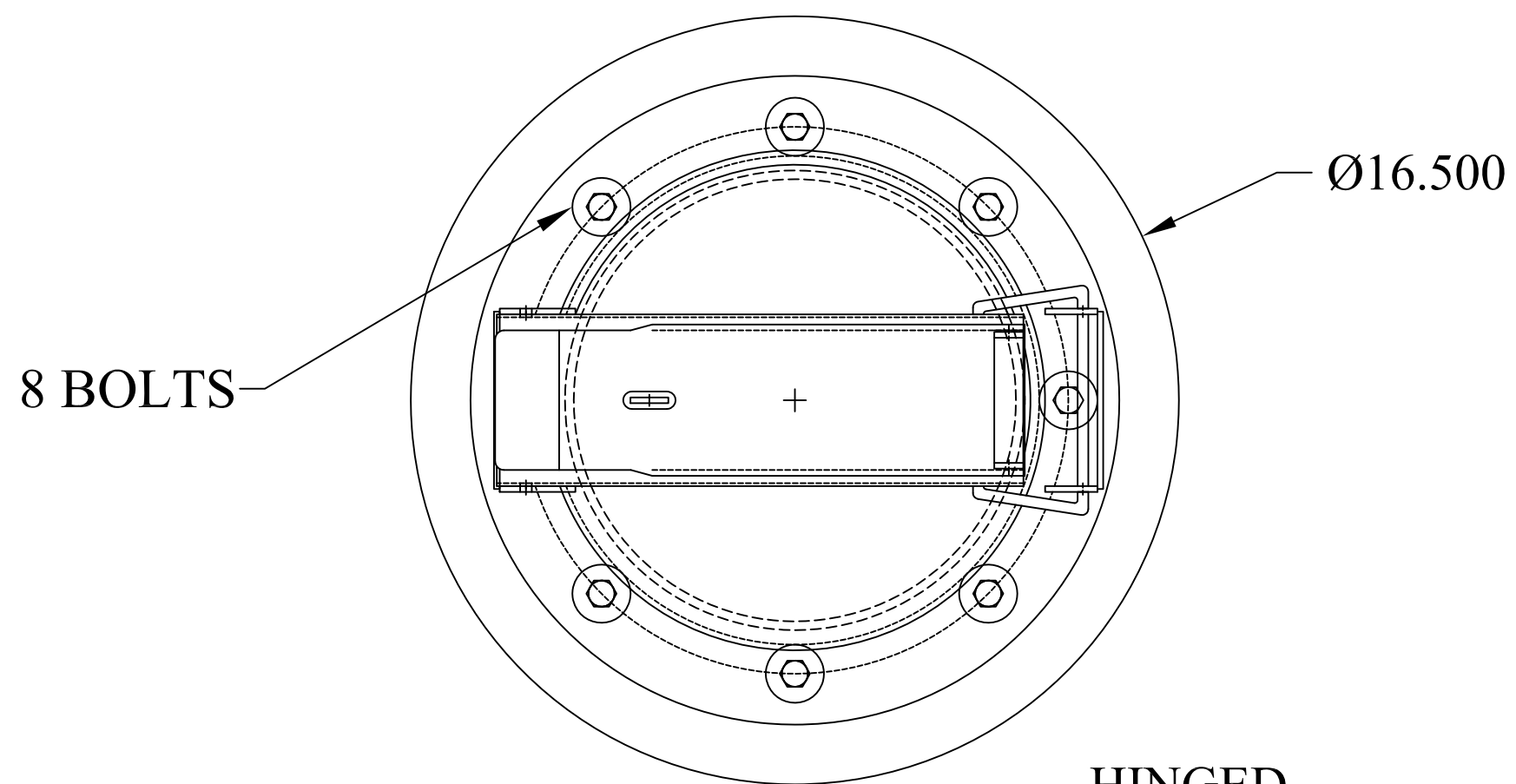

This document is proprietary and confidential. No part of this document may be disclosed in any manner to a third party without the prior written consent of Fairfield Industries

DO NOT SCALE DRAWING	
UNLESS OTHERWISE SPECIFIED, DIMENSIONS ARE IN INCHES.	
TOLERANCES ON ANGLES: ± 1°	
FRACTIONAL: ± 1/64	
2-PLACE DECIMALS: ± 0.05	
3-PLACE DECIMALS: ± 0.005	
THIRD ANGLE PROJECTION	

FAIRFIELD INDUSTRIES, INC					
4483 CHOPPEE ROAD, GEORGETOWN SC 29440					
PHONE: 843-461-3894			FAX: 843-461-3907		
DESCRIPTION BGSC-15					
SIZE C	SCALE NTS	DWG. NO D101920-7	C.REV -	REV 1	
DRAWN BY D NETTLES			DATE 10/20/20	SHT 1 OF 1	