

FEATURES:

1. 14GA. STAINLESS STEEL SPILL CONTAINER, 5 GALLON CAPACITY.
2. HINGED, WATER TIGHT, HATCH STYLE COVER ELIMINATES WATER AND DEBRIS. LOCKABLE FOR RESTRICTED ACCESS.
3. PUSH DRAIN
4. 4" NPT ADAPTORS FOR PIPING

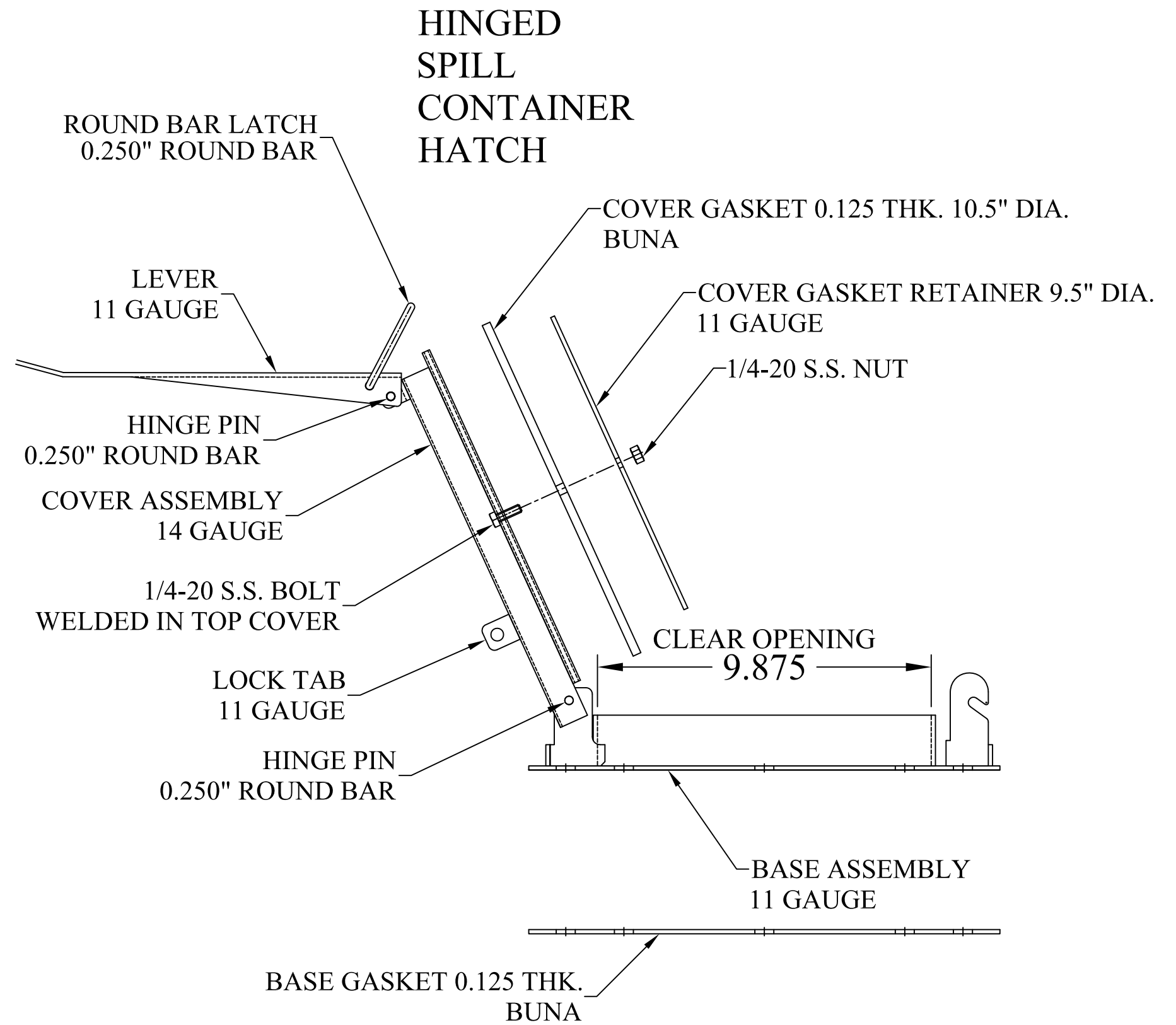
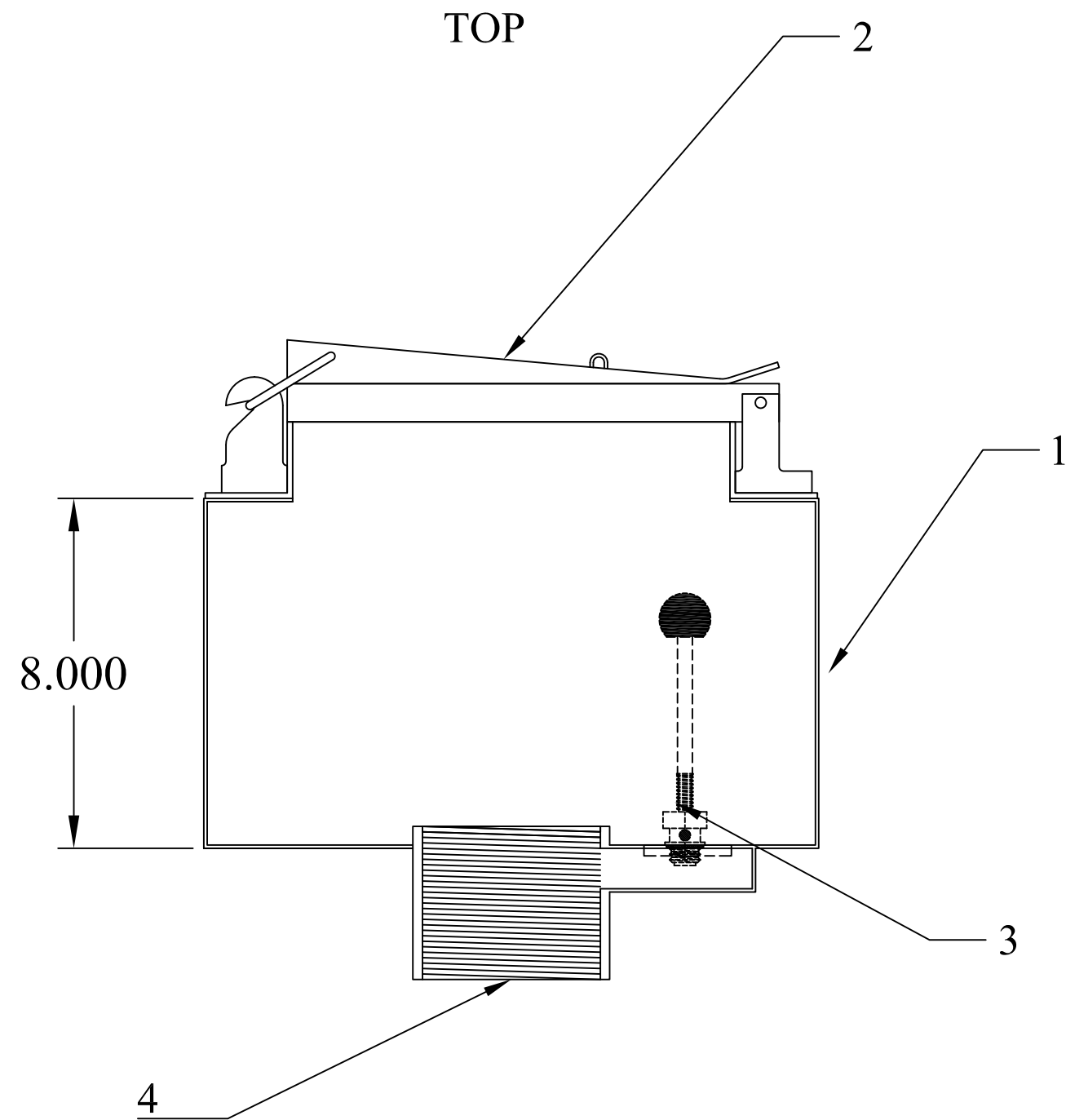

This document is proprietary and confidential. No part of this document may be disclosed in any manner to a third party without the prior written consent of Fairfield Industries

DO NOT SCALE DRAWING	
UNLESS OTHERWISE SPECIFIED, DIMENSIONS ARE IN INCHES.	
TOLERANCES ON ANGLES: ± 1°	
FRACTIONAL: ± 1/64	
2-PLACE DECIMALS: ± 0.05	
3-PLACE DECIMALS: ± 0.005	
THIRD ANGLE PROJECTION	

FAIRFIELD INDUSTRIES, INC					
4483 CHOPPEE ROAD, GEORGETOWN SC 29440					
PHONE: 843-461-3894			FAX: 843-461-3907		
DESCRIPTION					
BGSC-5					
SIZE	SCALE	DWG. NO	C.REV	REV	
C	NTS	D060419-3	-	1	
DRAWN BY		DATE	SHT		
D NETTLES		10/27/20	1 OF 1		