

FEATURES:

- 11 GAUGE 304 STAINLESS STEEL FRAME
- ONE (1) REMOVABLE 1/2" THICK DIAMOND PLATE COVER
- 1/8" THICK BUNA GASKET AND STAINLESS STEEL HARDWARE
- ONE (1) REMOVABLE, SCM-5-4" RETRO
- ONE (1) 4" FLEXIBLE ENTRY FITTING
- CHANNEL-STYLE CONCRETE ANCHORS
- MADE IN USA

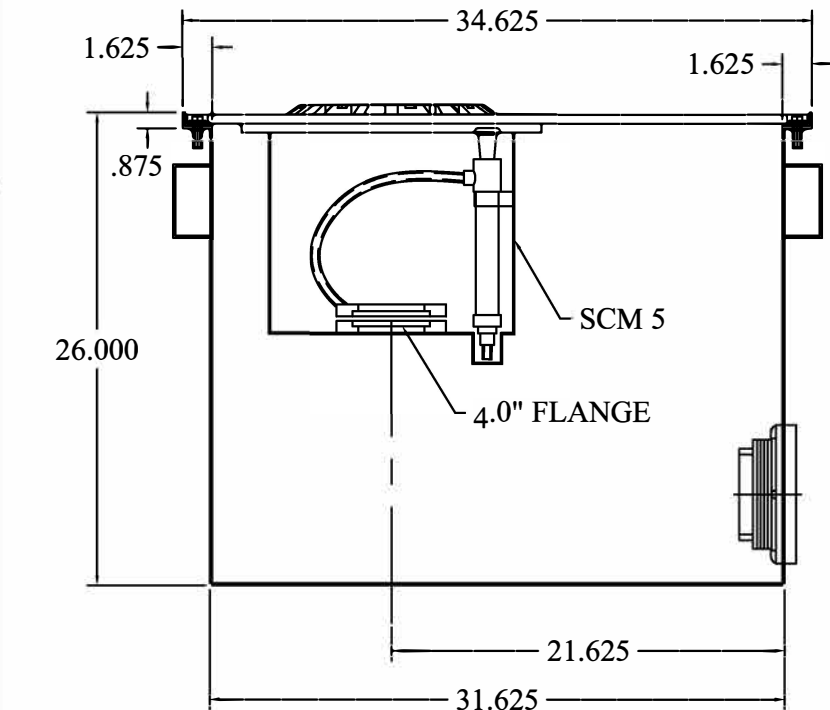

SECTION A-A

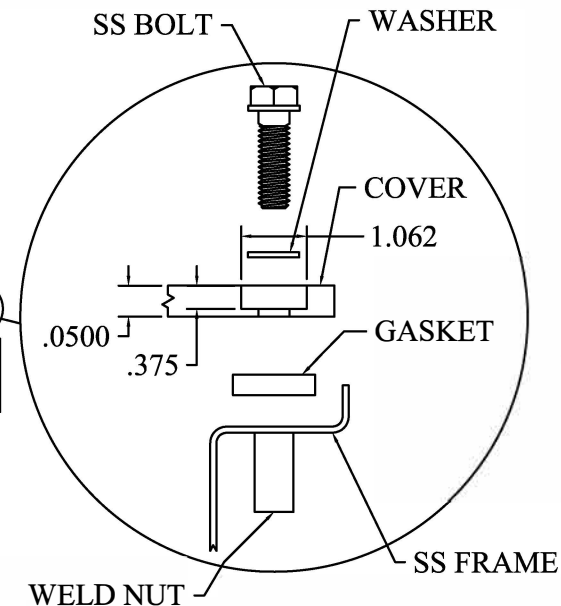
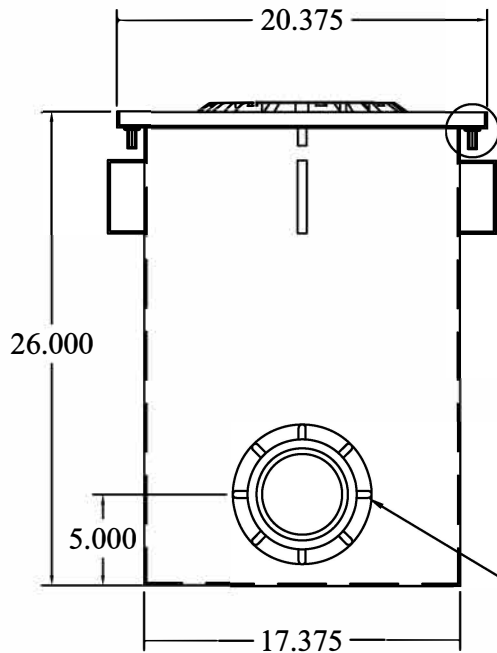

DO NOT SCALE DRAWING

UNLESS OTHERWISE SPECIFIED,
DIMENSIONS ARE IN INCHES.

TOLERANCES ON ANGLES: ± 0
 FRACTIONAL: ± 1/64
 2-PLACE DECIMALS: ± 0.05
 3-PLACE DECIMALS: ± 0.005

THIRD ANGLE PROJECTION



FAIRFIELD INDUSTRIES, INC

4483 CHOPPEE ROAD, GEORGETOWN SC 29440

PHONE: 843-461-3894 FAX: 843-461-3907

DESCRIPTION

RFTC-1

SIZE A	SCALE NTS	DWG. NO D101420-2	C.REV -	REV 1
DRAWN BY D NETTLES		DATE 10/14/20	SHT 1 OF 3	