

FEATURES:

- 14GA. STEEL SKIRT
- SELF-ALIGNING COVER AND BOLT HOLES FOR EASE OF INSTALLATION.
- DUCTILE IRON FRAME AND COVER
- STAINLESS STEEL HARDWARE
- .125" THICK BUNA-N GASKET
- OPTIONAL BRASS IDENTIFICATION TAG
- H-20 TRUCK-LOAD RATING
- MADE IN USA

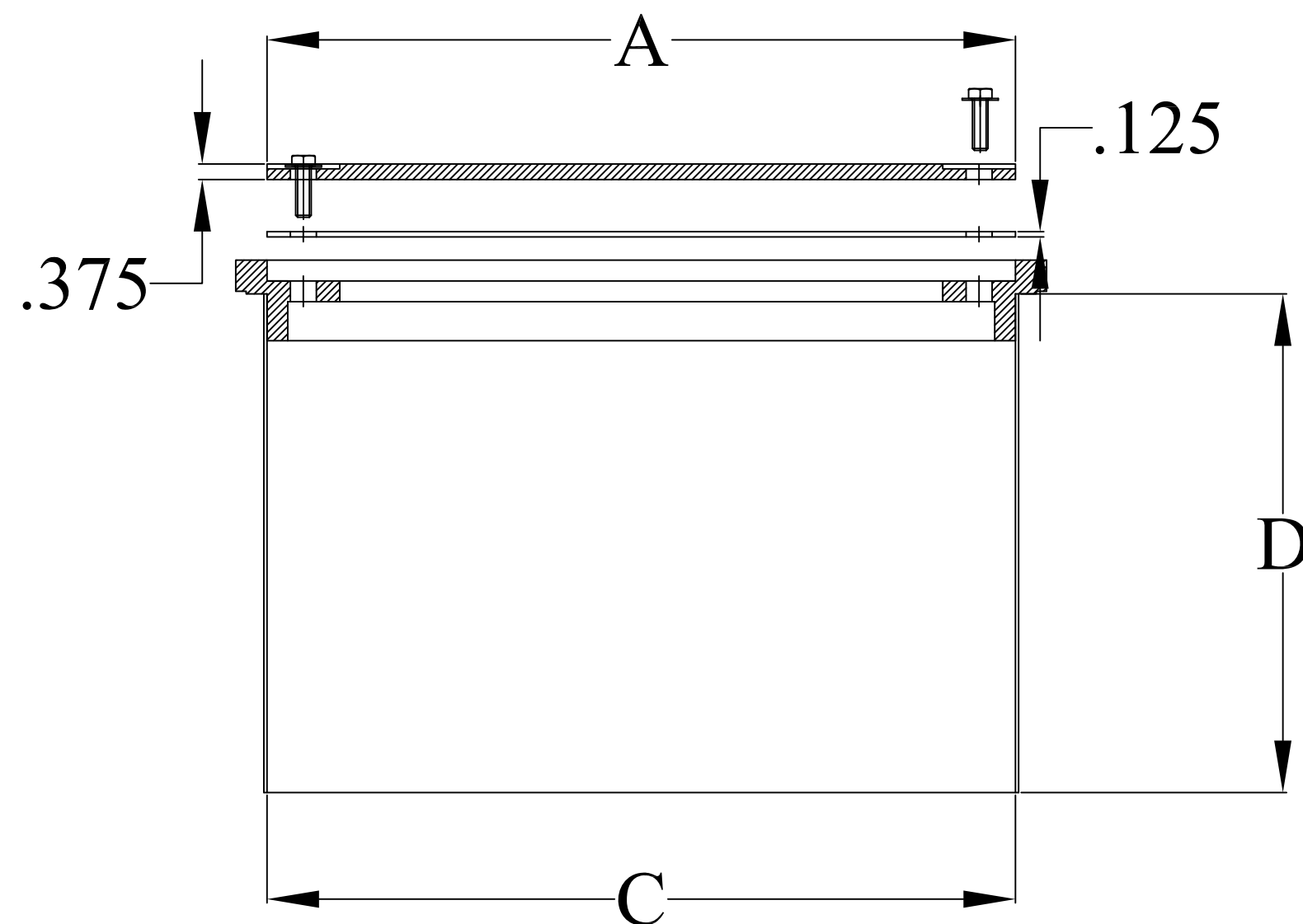

SMALL WATERTIGHT MANHOLES				
MODEL #	A	B	C	D
80-8-WT	8"	9"	8"	8"
80-12-WT	8"	9"	8"	12"
120-8-WT	12"	13"	12"	12"
120-12-WT	12"	13"	12"	12"
120-18-WT	12"	13"	12"	8"
180-8-WT	18"	19"	18"	8"
180-12-WT	18"	19"	18"	12"
180-18-WT	18"	19"	18"	18"

DO NOT SCALE DRAWING
 UNLESS OTHERWISE SPECIED
 DIMENSIONS ARE IN INCHES.
 TOLERANCES ON ANGLES: ± 1°
 FRACTIONAL: ± 1/16
 2-PLACE DECIMALS: ± 0.062
 3-PLACE DECIMAL: ± 0.032

FAIRFIELD INDUSTRIES, INC
 4483 CHOPPEE ROAD, GEORGETOWN SC 29440
 PHONE: 843-461-3894 FAX: 843-461-3907

DESCRIPTION
SMALL WATERTIGHT MANHOLES

THIRD ANGLE PROJECTION

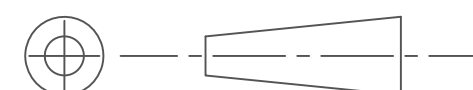

SIZE C	SCALE NTS	DWG.NO. D102618-2	REV. 1
DRAWN BY D NETTLES		DATE 10/26/18	SHT. 1 OF 1

This document is proprietary and confidential. No part of this document may be disclosed in any manner to a third party without the prior written consent of Fairfield Industries