

18" ROUND SIDEWALK SPILL CONTAINER

FEATURES:

- 3/8" THICK DIAMOND PLATE COVER
- .125" THICK BUNA GASKET
- ONE (1) FLEXIBLE ENTRY FITTING
- ONE (1) SINGLE STROKE PVC HAND PUMP
- 14 GAUGE 304 STAINLESS STEEL SKIRT AND BOTTOM
- FOUR (4) CAM LOCKS
- ONE RECESSED WATER TIGHT HANDLE
- ONE 3/4" 304 STAINLESS STEEL NPT CONDUIT COUPLING
- MADE IN USA

OPTIONS:

- AVAILABLE IN 2", 3" AND 4"
- ADDITIONAL FLEX BOOTS

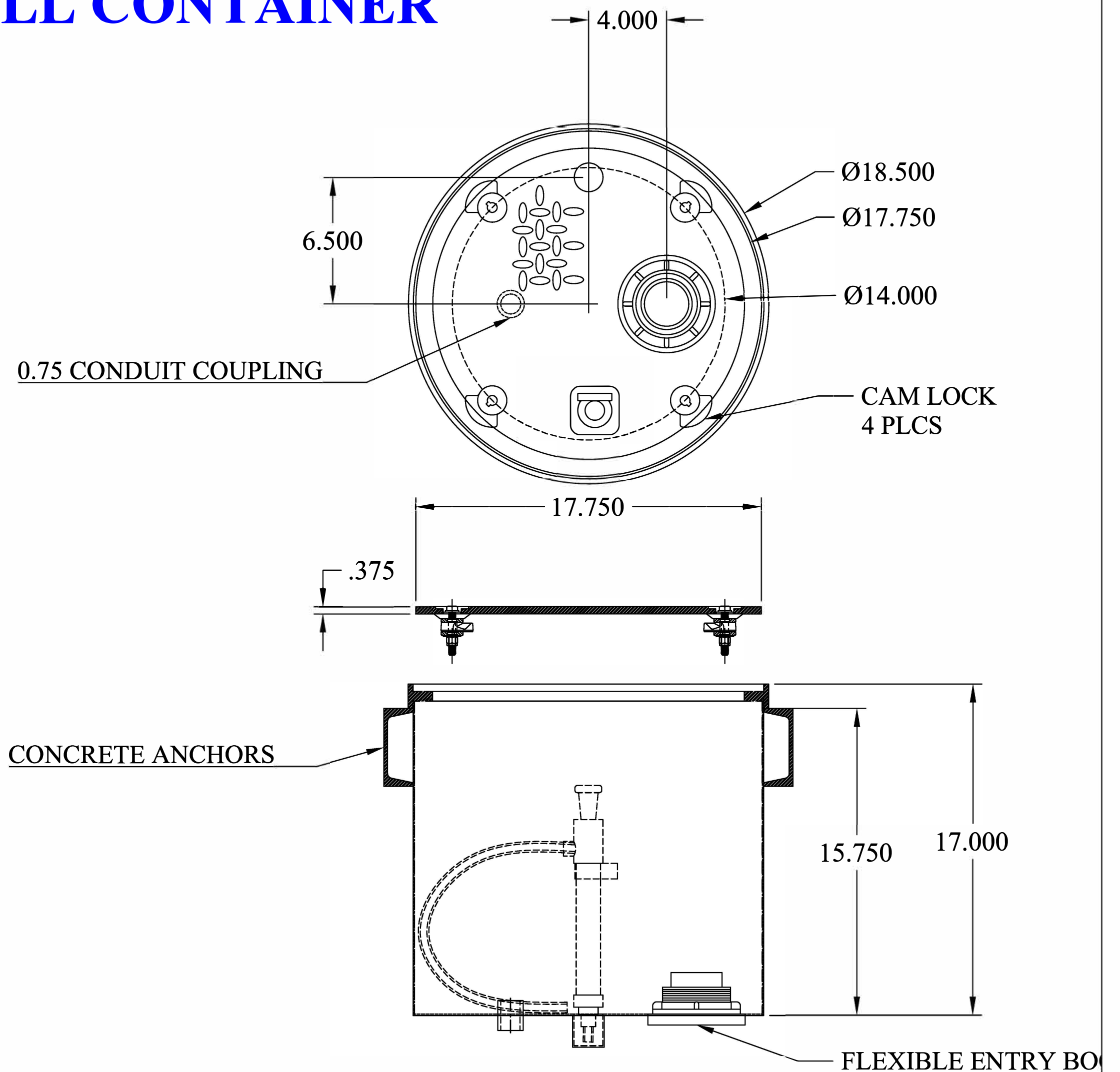

CHECK OPTIONS AND SUBMIT WITH ORDER *ES*

SSC-18-2	2"	
SSC-18-3	3"	
SSC-18-4	4"	
ADDITIONAL BOOT		

This document is proprietary and confidential. No part of this document may be disclosed in any manner to a third party without the prior written consent of Fairfield Industries

DO NOT SCALE DRAWING
UNLESS OTHERWISE SPECIED
DIMENSIONS ARE IN INCHES.
TOLERANCES ON ANGLES: ± 1°
FRACTIONAL: ± 1/16
2-PLACE DECIMALS: ± 0.062
3-PLACE DECIMAL: ± 0.032

THIRD ANGLE PROJECTION



FAIRFIELD INDUSTRIES, INC
4483 CHOPPEE ROAD, GEORGETOWN SC 29440
PHONE: 843-461-3894 FAX: 843-461-3907

DESCRIPTION		SSC-18	
SIZE	SCALE	DWG.NO.	REV.
C	NTS	D082918-2	1
DRAWN BY		DATE	SHT.
D NETTLES		08/29/18	1 OF 1