

# SSC24 SERIES

## 24" ROUND SIDEWALK SPILL CONTAINER

### FEATURES:

- 3/8" THICK DIAMOND PLATE COVER
- 3/16" THICK 40 DURO BUNA-RING GASKET 24-3/16" OD. X 22-3/16" ID.
- ONE (1) DPM FLEXIBLE ENTRY FITTING
- ONE (1) SINGLE STROKE PVC HAND PUMP
- 14 GAUGE 304 STAINLESS STEEL SKIRT AND BOTTOM
- FIVE (5) CAM LOCKS
- ONE RECESSED WATER TIGHT HANDLE
- ONE 3/4" 304 STAINLESS STEEL NPT CONDUIT COUPLING
- MADE IN USA

### OPTIONS:

- AVAILABLE IN 2", 3" AND 4"
- 17.25" X 12" ALARM PANEL (AMP)
- ADDITIONAL FLEX BOOTS
- ADDITIONAL CONDUIT COUPLINGS (CC)
- I.D.TAG

OPTIONAL  
ALARM PANEL

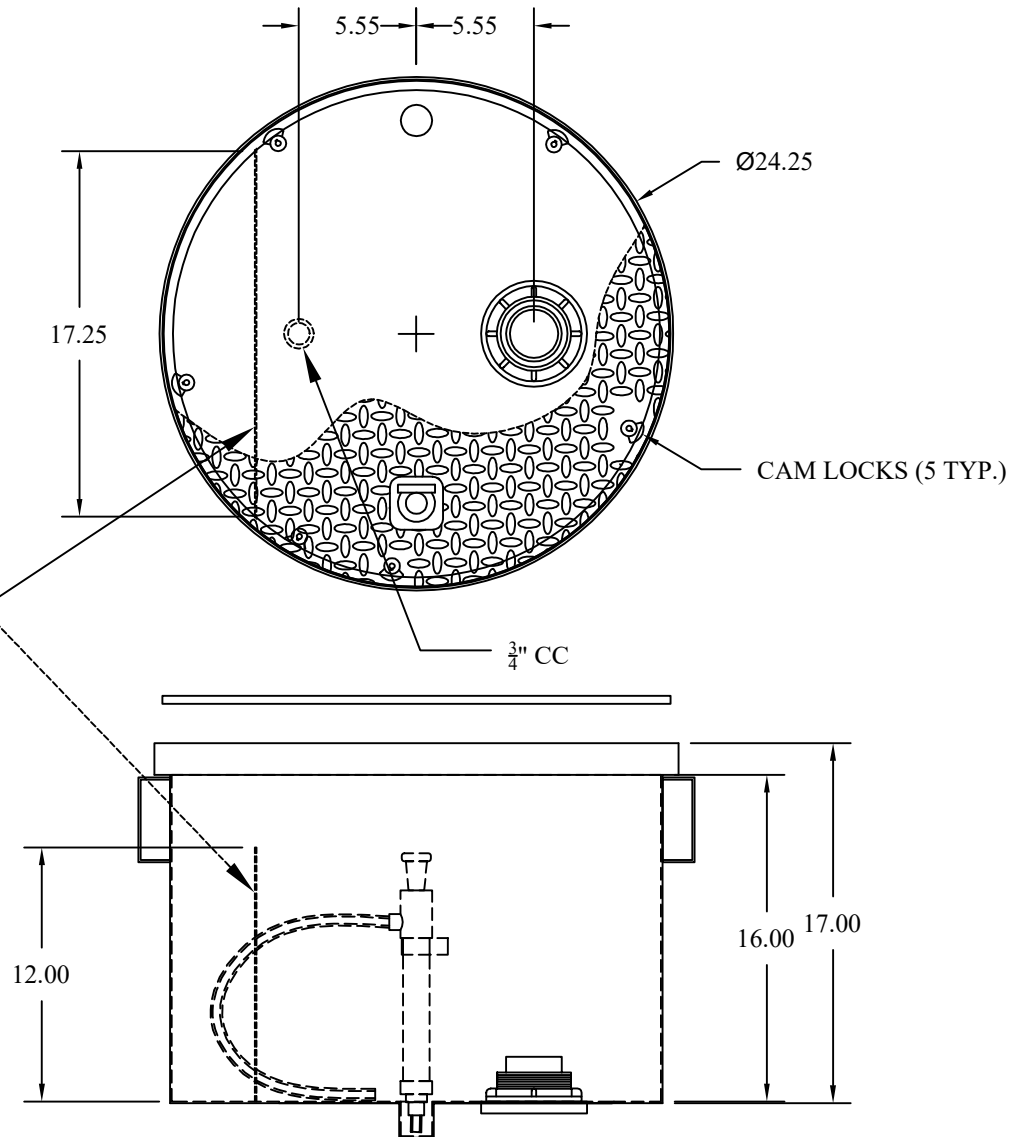

### CHECK OPTIONS AND SUBMIT WITH ORDER

SSC24-2	2"	
SSC24-3	3"	
SSC24-4	4"	
ALARM PANEL		
ADDITIONAL CC		
ADDITIONAL BOOT		

DO NOT SCALE DRAWING  
UNLESS OTHERWISE SPECIFIED,  
DIMENSIONS ARE IN INCHES.

TOLERANCES ON ANGLES: ± 0  
FRACTIONAL: ± 1/64  
2-PLACE DECIMALS: ± 0.05  
3-PLACE DECIMALS: ± 0.005

THIRD ANGLE PROJECTION

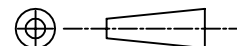

FAIRFIELD INDUSTRIES, INC

4483 CHOPPEE ROAD, GEORGETOWN SC 29440

PHONE: 843-461-3894 FAX: 843-461-3907

SSC 24

SIZE A	SCALE NTS	DWG. NO 072215	C.REV -	REV 2
DRAWN BY A. CONKLIN		DATE 12/06/16	SHT 1 OF 1	