

DP SERIES

DISPENSER CONTAINMENT PLATFORMS

SPECIFICATION:

FAIRFIELD INDUSTRIES - DISPENSER PLATFORMS (DP) ARE UTILIZED FOR THE MOUNTING AND PLUMBING OF FUEL DISPENSERS TIED TO ABOVE GROUND STORAGE TANKS.

THE STAINLESS STEEL CONTAINMENT PLATFORM IS PAD MOUNTABLE AND HOUSES CONTRACTOR FURNISHED SHEAR VALVES OR PRESSURE REGULATING VALVES COMMON TO DISPENSER INSTALLATIONS. ANY LEAKAGE FROM DISPENSER OR DOUBLE WALL PIPING IS CONTAINED INSIDE THE CONTAINMENT AREA.

UNITS ARE AVAILABLE FOR VARIOUS DISPENSER MANUFACTURERS OF SINGLE OR DUAL PRODUCT APPLICATIONS WITH FLEXIBLE ENTRY BOOTS OF 1.5" OR 2" PENETRATIONS.

OPTIONAL ELECTRICAL PENETRATIONS AND VAPOR PENETRATIONS AVAILABLE.

FEATURES:

- SIZE: SINGLE 25" W X 21.25" D X 17.25" H
DUAL: 30.35" W X 21.24" D X 17.25" H
- HEAVY GAUGE STAINLESS STEEL MAINTENANCE-FREE CONTAINMENT PLATFORM
- ADJUSTABLE STABILIZER BAR WITH BOLT-ON SHEAR VALVE BRACKET
- (4) ANCHOR FEET WITH BOLT HOLES
- 1.5" OR 2" FLEXIBLE PRODUCT PENETRATION BOOTS FACTORY INSTALLED (SPECIFY WHEN ORDERING)
- GOOD FOR SUCTION OR PRESSURIZED PIPING SYSTEMS
- VARIOUS DISPENSER FOOT PRINTS AVAILABLE W/ DISPENSER ANCHOR POINS

OPTIONAL:

- REAR ACCESS PANELS
- TOK 52 VALVE BRACKET
- 3/4" OR 1" ELECTRICAL PENETRATION FITTINGS
- 1-1/2" STAGE II VAPOR PENETRATION FITTING
- DOUBLE WALL PIPE PENETRATION FITTING

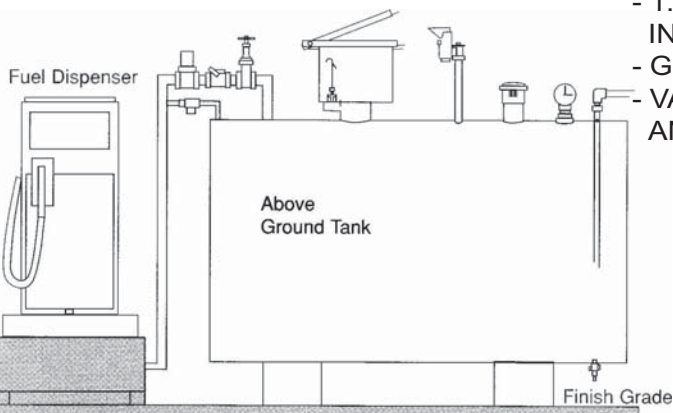

#DP-1
Dispenser Containment Platform

MODEL: DP

DISPENSER CONTAINMENT PLATFORM

NOTE:

FAIRFIELD INDUSTRIES, INC.

4483 CHOPPEE ROAD GEORGETOWN, SC 29440

PHONE: 843-461-3894 FAX: 843-461-3894

www.fairfield-industries.com

Copyright © 2008 Fairfield Industries, Inc. All rights reserved

DP SERIES DISPENSER CONTAINMENT PLATFORMS

DISPENSER PLATFORM SELECTION GUIDE

MODEL	DESCRIPTION	
DP-1	SINGLE PRODUCT A/G DISPENSER PLATFORMS	
DP-2	DUAL PRODUCT A/G DISPENSER PLATFORMS	
OPTIONS:	PART NUMBER:	DESCRIPTION:
	TOK	TOKHIEM OR EBW VALVE BRACKET
	RAP	REAR ACCESS PANEL
	VR	1 1/2" NPT WELDED VAPOR RECOVERY PENETRATION FITTING
	CC	3/4" CONDUIT COUPLING WELDED WHERE REQUIRED
	DWP	DOUBLE WALL PIPING PENETRATION FITTING

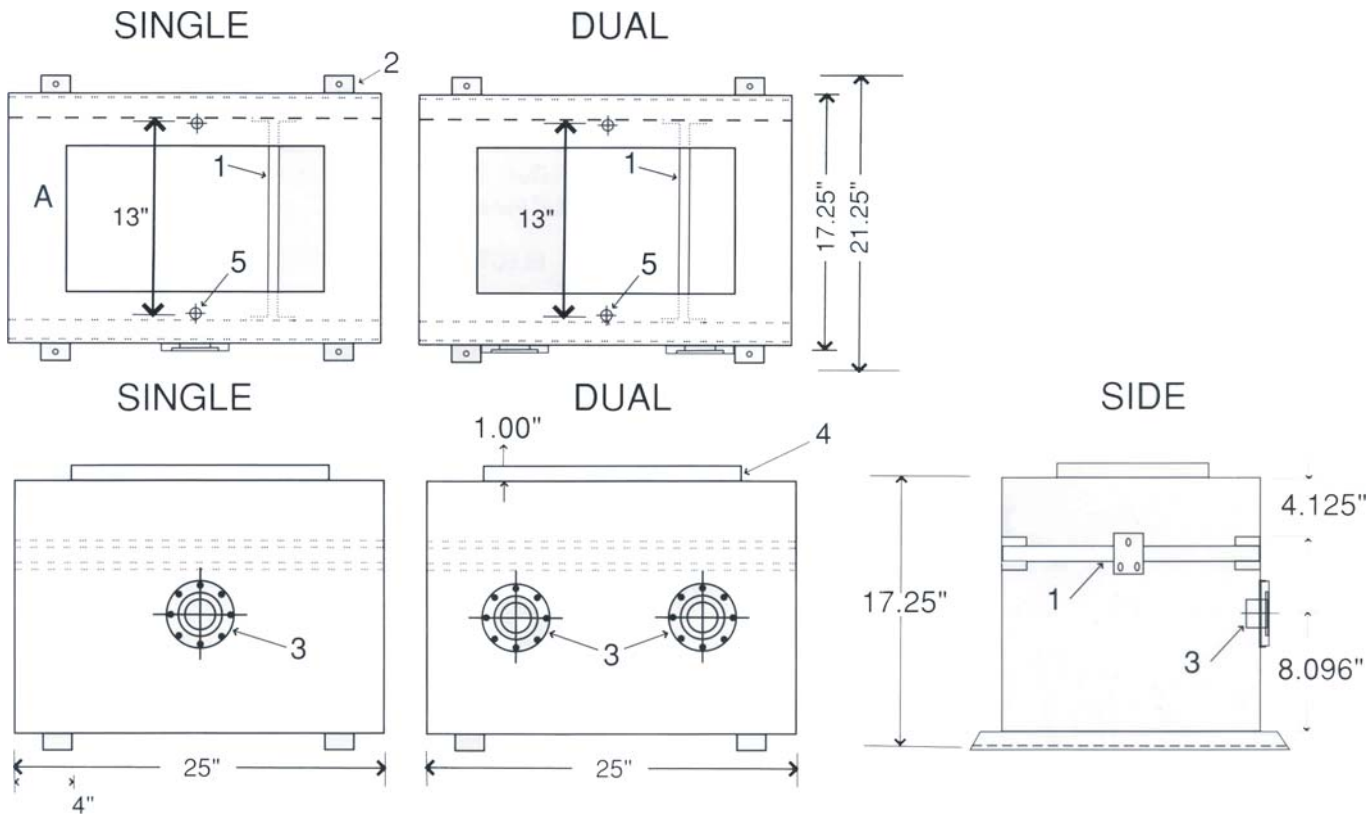

DP PARTS GUIDE

ITEM	OPT/STD	DESCRIPTION
A	STD	STAINLESS STEEL DISPENSER CONTAINMENT PLATFORM
1	STD	SINGLE OR DUAL ADJUSTABLE STABILIZER BARS W/BOLT ON STYLE SHEAR VALVE BRACKETS
2	STD	(4) ANCHOR CLIPS FOR 1/2" ANCHOR BOLTS
3	STD	SINGLE OR DUAL FLEXIBLE PENETRATION FITTINGS SPECIFY 1-1/2" OR 2" PIPING SIZE
4	STD	RAIN LIP 1"
5	STD	DISPENSER ANCHOR POINTS

NOTE: CUSTOMER TO SPECIFY ACTUAL DISPENSER MFRG. AND MODEL NUMBER (OR DISPENSER FOOTPRINT) FOR PROPER APPLICATION.