

MW SERIES

MONITOR WELL MANHOLES 50-MW-5

STANDARD FEATURES

- SIZE: 5" DIAMETER FOR 2" AND 4" PVC MONITOR WELLS.
- SELF ALIGNING COVER AND BOLT HOLES FOR EASE OF INSTALLATION & REMOVAL.
- DUCTILE IRON CAST FRAME & COVER
- 14 GAUGE STEEL SKIRTS.
- API TRIANGULAR SYMBOL AND THE WORDS "MONITORING WELL" AND "DO NOT FILL" CAST INTO COVER.
- STAINLESS STEEL HEX HEAD BOLTS SECURE COVER FOR LIMITED ACCESS AND UNAUTHORIZED PRODUCT DROPS.
- BUNA-N GASKET FORMS WATERTIGHT SEAL PREVENTING RUN-OFF CONTAMINATION.
- TOLERANCE + OR - 1/8" SUBJECT TO CHANGE WITHOUT NOTICE.

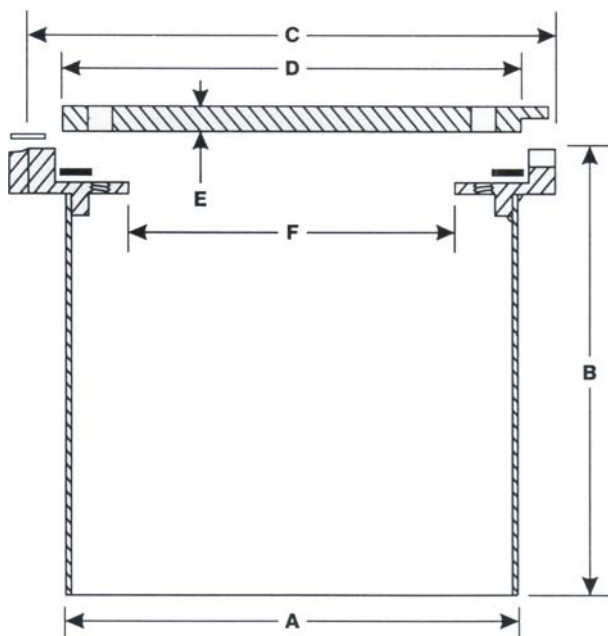

MONITOR WELL MANHOLES WATERTIGHT						
MODEL	A	B	C	D	E	F
50-MW-5	5"	5"	6 3/8"	5 1/4"	1/2"	3"

SECTION AA

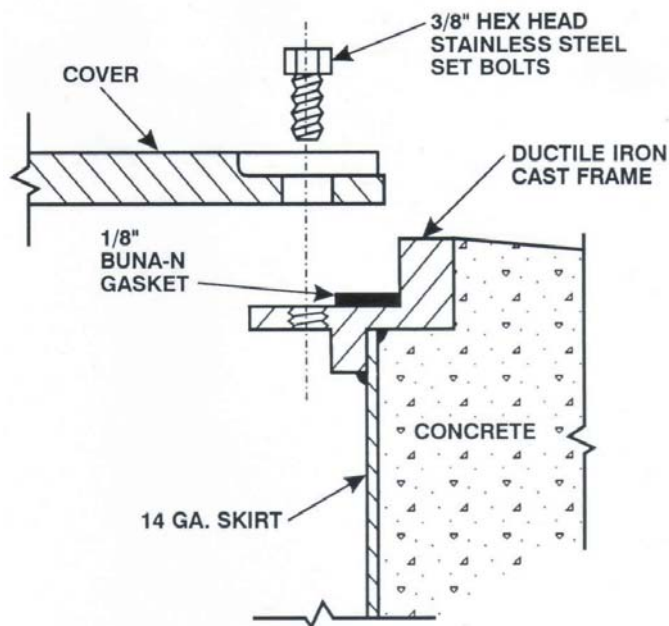

MODEL NO: 50-MW-50

MW
MONITOR WELL MANHOLES
50-MW-5

FAIRFIELD INDUSTRIES, INC.

4483 CHOPPEE ROAD, SC 29440
PHONE: 843-461-3984 FAX: 843-461-3907
www.fairfield-industries.com