

**FEATURES:**

- SPECIALLY DESIGNED WATER TIGHT FRAME & COVER ASSEMBLY CAST OF TOUGH DURABLE DUCTILE IRON. DETERS SURFACE WATERS WITH THE USE OF BUNA-N O-RINGS.
- REMOVABLE 14 GA. CARBON STEEL 5 GALLON PRIMARY SPILL CONTAINERONE (1) 4" FLANGE ASSEMBLY WITH BUNA SEAL AND STAINLESS STEEL HARDWARE.
- ONE (1) 1 1/2" SENSOR INSPECTION PLUG WITH BUNA O-RING
- OPTIONAL PVC SINGLE STROKE HAND PUMP
- REMOVABLE STEEL T-FRAME CONSTRUCTION 14 GA. CARBON STEEL SECONDARY STEEL SPILL CONTAINER WITH 0.375 THK. DIAMOND PLATE SUPPORT RING
- 4" VICTUAL DOUBLE-SEALING GASKET AND FLANGE ASSEMBLY
- INCLUDES GEMS LS-3 SERIES LEVEL SWITCH (TWO WIRE LEAK SENSOR)
- ONE (1) 3/4" NPT CONDUIT FITTING WITH CORD GRIP STRAIN RELIEF.
- PAINTED BLACK
- HDPE GRAVEL GUARD

CUSTOM BUNA-N DOVE TAIL O-RING

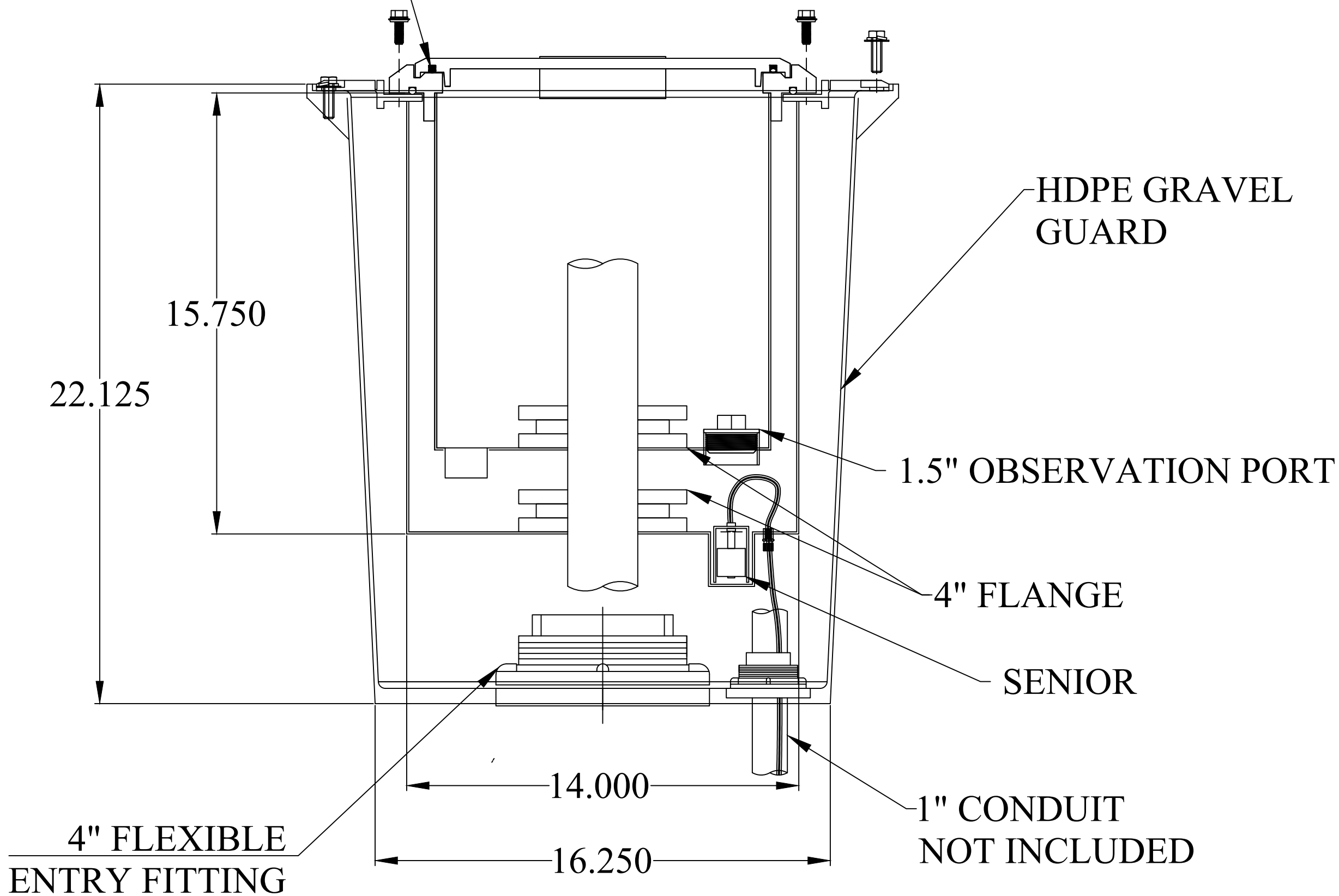

**DO NOT SCALE DRAWING**

UNLESS OTHERWISE SPECIED  
DIMENSIONS ARE IN INCHES.  
TOLERANCES ON ANGLES: ± 1°  
FRACTIONAL: ± 1/16  
2-PLACE DECIMALS: ± 0.062  
3-PLACE DECIMAL: ± 0.032

THIRD ANGLE PROJECTION

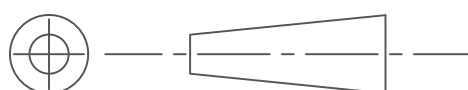

**FAIRFIELD INDUSTRIES, INC**

4483 CHOPPEE ROAD, GEORGETOWN SC 29440  
PHONE: 843-461-3894 FAX: 843-461-3907

DESCRIPTION

**SCM 5D-NCGG**

|            |       |           |        |
|------------|-------|-----------|--------|
| SIZE       | SCALE | DWG.NO.   | REV.   |
| C          | NTS   | D062821-1 | 1      |
| DRAWN BY   |       | DATE      | SHT.   |
| D. NETTLES |       | 06/28/21  | 1 OF 1 |

This document is proprietary and confidential. No part of this document may be disclosed in any manner to a third party without the prior written consent of Fairfield Industries