

SCM-5-ZRC3

SPILL CONTAINMENT REPAIR KIT

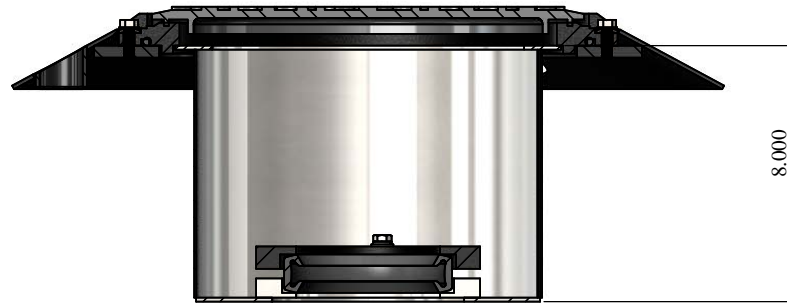

SECTION A-A
SCALE 1 : 3

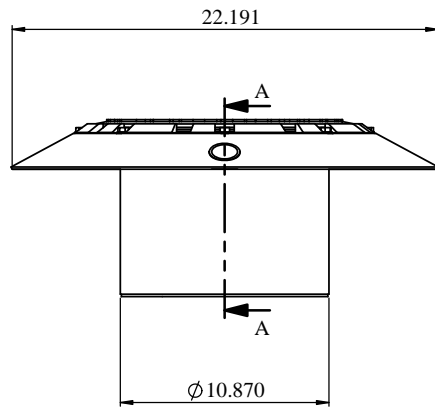
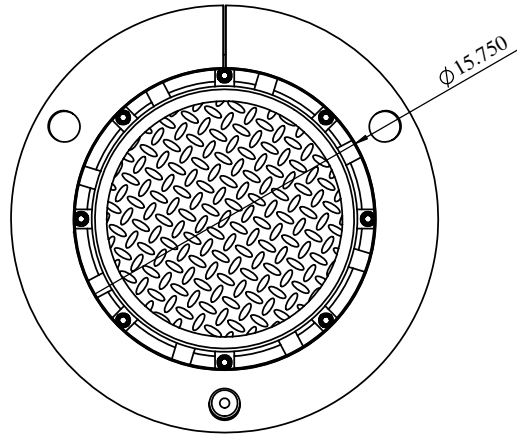
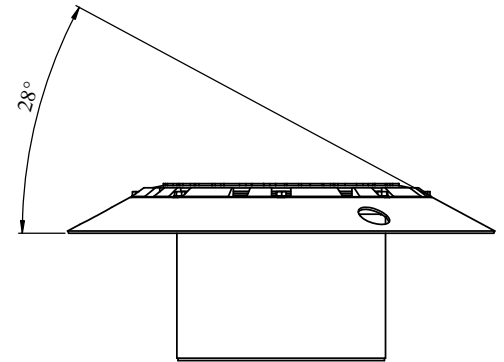

DO NOT SCALE DRAWING

UNLESS OTHERWISE SPECIED
DIMENSIONS ARE IN INCHES.
TOLERANCES ON ANGLES: $\pm 1^\circ$
FRACTIONAL: $\pm 1/16$
2-PLACE DECIMALS: ± 0.062
3-PLACE DECIMAL: ± 0.032

THIRD ANGLE PROJECTION



FAIRFIELD INDUSTRIES, INC

4483 CHOPPEE ROAD, GEORGETOWN SC 29440
PHONE: 843-461-3894 FAX: 843-461-3907

DESCRIPTION SCM-5-ZRC3

This document is proprietary and confidential. No part of this document may be disclosed in any manner to a third party without the prior written consent of Fairfield Industries

SIZE C	SCALE NA	DWG.NO. D020320-1	REV. 1
DRAWN BY D. NETTLES	DATE 3/2/20	SHT. 1 OF 2	



ITEM NO.	PART NUMBER	DESCRIPTION	EXPLODED VIEW /QTY.
1	SCM FRAME	CARBON STEEL POWDER COATED BLACK	1
2	ZRC SPILL CONTAINER ASSEMBLY	CARBON STEEL 12" DEEP POWDER COATED BLACK	1
3	SCM COVER	DUCTILE IRON	1
4	SCM RING HARDWARE	SS BOLTS AND WASHERS	8
5	CAST RING - O-RING	BUNA O-RING	1
6	SCM-5-4- SEAL	SCM 5 4" SEAL	1
7	SCM-TOP-FLANGE	CAST STEEL	1
10	HFBOLT 0.3125-24x1.5x0.875-S	SS BOLTS AND WASHERS	3

DO NOT SCALE DRAWING

UNLESS OTHERWISE SPECIED
DIMENSIONS ARE IN INCHES.
TOLERANCES ON ANGLES: ± 1°
FRACTIONAL: ± 1/16
2-PLACE DECIMALS: ± 0.062
3-PLACE DECIMAL: ± 0.032

THIRD ANGLE PROJECTION



FAIRFIELD INDUSTRIES, INC

4483 CHOPPEE ROAD, GEORGETOWN SC 29440
PHONE: 843-461-3894 FAX: 843-461-3907

DESCRIPTION SCM-5-ZRC3

This document is proprietary and confidential. No part of this document may be disclosed in any manner to a third party without the prior written consent of Fairfield Industries

SIZE C	SCALE NA	DWG.NO. D030220-1	REV. 1
DRAWN BY D. NETTLES		DATE 3/2/20	SHT. 2 OF 2